



US010221609B2

(12) **United States Patent**  
**Yulkowski et al.**

(10) **Patent No.:** **US 10,221,609 B2**  
(45) **Date of Patent:** **\*Mar. 5, 2019**

(54) **CONCEALED ELECTRICAL DOOR OPERATOR**

(75) Inventors: **Leon Yulkowski**, Bloomfield Hills, MI (US); **Gerard Edwards**, Centerville, OH (US); **Steve Gebhart**, Tipp City, OH (US)

(73) Assignees: **Leon Yulkowski**, Bloomfield Hills, MI (US); **Globe Motors, Inc.**, Dayton, OH (US)

(\* ) Notice: Subject to any disclaimer, the term of this patent is extended or adjusted under 35 U.S.C. 154(b) by 0 days.  
  
This patent is subject to a terminal disclaimer.

(21) Appl. No.: **13/589,471**

(22) Filed: **Aug. 20, 2012**

(65) **Prior Publication Data**  
US 2013/0118079 A1 May 16, 2013

**Related U.S. Application Data**

(63) Continuation of application No. 12/416,622, filed on Apr. 1, 2009, now Pat. No. 8,261,491.  
(Continued)

(51) **Int. Cl.**  
**E05F 15/63** (2015.01)  
**E05F 15/00** (2015.01)  
(Continued)

(52) **U.S. Cl.**  
CPC ..... **E05F 15/63** (2015.01); **E05F 15/00** (2013.01); **E05F 15/70** (2015.01); **E05F 15/41** (2015.01);  
(Continued)

(58) **Field of Classification Search**  
CPC ..... E05F 15/00; E05F 15/70; E05F 15/63  
(Continued)

(56) **References Cited**  
U.S. PATENT DOCUMENTS

1,684,704 A 9/1928 Hubbell  
3,039,764 A 6/1962 Heinsman et al.  
(Continued)

FOREIGN PATENT DOCUMENTS

DE 10 2007 038 421 9/2008  
WO 2008/078029 7/2008

OTHER PUBLICATIONS

5 Pages, May 1, 2012, U.S. Appl. No. 12/719,954.  
(Continued)

*Primary Examiner* — Katherine W Mitchell  
*Assistant Examiner* — Marcus Menezes  
(74) *Attorney, Agent, or Firm* — Evan Law Group LLC

(57) **ABSTRACT**

A door assembly includes a first door skin, a second door skin spaced apart from the first door skin and a door operator disposed between the first door skin and the second door skin. An arm extends from the door operator. The door operator includes a motor moving the arm to move the door between a closed position and an open position and between the open position and the closed position. A current sensor generates a current signal corresponding to the current to the motor. A position sensor in communication with the door arm generates a position signal corresponding to the position of the door relative to the frame. A controller communicates with the sensor and the motor. The controller controls a motor current to the motor in response to the current signal and the position signal.

**22 Claims, 6 Drawing Sheets**

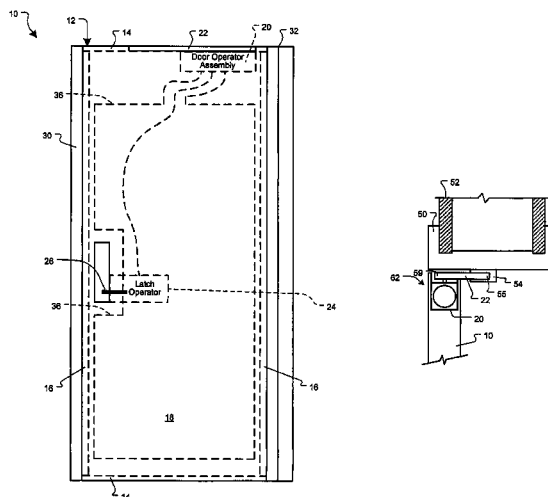

| <b>Related U.S. Application Data</b> |   |  |   |  |                          |
|--------------------------------------|---|--|---|--|--------------------------|
|                                      |   | 7,070,226 B2 *   | 7/2006  | Cleland et al. ....  | 296/146.8                |
|                                      |   | 7,143,548 B2   | 12/2006   | Kleinmann et al.   |                          |
|                                      |   | 7,145,436 B2   | 12/2006   | Ichikawa et al.  |                          |
|                                      |   | 7,224,275 B2   | 5/2007  | Fitzgibbon   |                          |
|                                      |   | 7,263,802 B2   | 9/2007  | Fitzgibbon et al.  |                          |
|                                      |   | 7,316,096 B2   | 1/2008  | Houser et al.  |                          |
|                                      |   | 7,382,063 B2   | 6/2008  | Mullet et al.  |                          |
|                                      |   | 7,418,800 B1   | 9/2008  | Sellman  |                          |
|                                      |   | 7,493,726 B2   | 2/2009  | Fitzgibbon et al.  |                          |
|                                      |   | 7,999,690 B1   | 8/2011  | Shilts   |                          |
|                                      |   | 8,261,491 B2   | 9/2012  | Yulkowski et al.   |                          |
|                                      |   | 8,405,337 B2 *   | 3/2013  | Gebhart .....  | H02P 6/085<br>318/400.01 |
| (60)                                 | Provisional application No. 61/041,696, filed on Apr. 2, 2008, provisional application No. 61/054,952, filed on May 21, 2008.   |  |   |  |                          |
| (51)                                 | <b>Int. Cl.</b>   |  |   |  |                          |
|                                      | <i>E05F 15/70</i> (2015.01)   |  |   |  |                          |
|                                      | <i>E05F 15/41</i> (2015.01)   |  |   |  |                          |
|                                      | <i>E05F 15/73</i> (2015.01)   |  |   |  |                          |
| (52)                                 | <b>U.S. Cl.</b>   |  |   |  |                          |
|                                      | CPC ..... <i>E05F 15/73</i> (2015.01); <i>E05Y 2400/302</i> (2013.01); <i>E05Y 2400/31</i> (2013.01); <i>E05Y 2400/326</i> (2013.01); <i>E05Y 2400/45</i> (2013.01); <i>E05Y 2400/51</i> (2013.01); <i>E05Y 2400/514</i> (2013.01); <i>E05Y 2400/532</i> (2013.01); <i>E05Y 2400/554</i> (2013.01); <i>E05Y 2400/612</i> (2013.01); <i>E05Y 2600/41</i> (2013.01); <i>E05Y 2900/132</i> (2013.01) | 8,653,982 B2<br>8,844,200 B2<br>8,907,791 B2<br>9,536,357 B2<br>2002/0026750 A1<br>2002/0092237 A1<br>2002/0104266 A1<br>2002/0178655 A1<br>2003/0005639 A1<br>2003/0213177 A1<br>2003/0217894 A1<br>2004/0046418 A1<br>2004/0187387 A1<br>2004/0251868 A1<br>2005/0091928 A1<br>2005/0198063 A1<br>2005/0217097 A1<br>2006/0167656 A1<br>2006/0197481 A1<br>2006/0244271 A1<br>2006/0267409 A1<br>2006/0293821 A1<br>2007/0108927 A1<br>2007/0193220 A1<br>2008/0061963 A1<br>2008/0168714 A1<br>2008/0203760 A1<br>2008/0209228 A1<br>2008/0246607 A1<br>2009/0185197 A1<br>2009/0186736 A1<br>2009/0249699 A1<br>2010/0114525 A1<br>2010/0242368 A1<br>2011/0016971 A1<br>2013/0199321 A1<br>2014/0182206 A1<br>2015/0059249 A1<br>2015/0137963 A1<br>2016/0115725 A1<br>2016/0273617 A1<br>2017/0152696 A1 | 2/2014<br>9/2014<br>12/2014<br>1/2017<br>3/2002<br>7/2002<br>8/2002<br>12/2002<br>1/2003<br>11/2003<br>11/2003<br>3/2004<br>9/2004<br>12/2004<br>5/2005<br>9/2005<br>10/2005<br>7/2006<br>9/2006<br>11/2006<br>11/2006<br>12/2006<br>5/2007<br>8/2007<br>3/2008<br>7/2008<br>8/2008<br>8/2008<br>10/2008<br>7/2009<br>7/2009<br>10/2009<br>5/2010<br>9/2010<br>1/2011<br>8/2013<br>7/2014<br>3/2015<br>5/2015<br>4/2016<br>9/2016<br>6/2017 | Yulkowski et al.<br>Yulkowski et al.<br>Yulkowski et al.<br>Yulkowski et al.<br>St. John et al.<br>Hebda<br>Ranaudo<br>Pedemonte<br>Kowaiczuk<br>Fitzgibbon et al.<br>Perala et al.<br>Chikata<br>Hedrich<br>Sato et al.<br>Okulov<br>Thomas et al.<br>Solfronk<br>Shimonishi<br>Hotto et al.<br>Hass<br>Mullet et al.<br>Takahashi<br>Valencia et al.<br>Daniels<br>Schnitz et al.<br>Watanabe<br>Cafeo et al.<br>Chandler<br>Smith<br>Wilson et al.<br>Ta<br>Yulkowski<br>Ollivier et al.<br>Yulkowski<br>Yulkowski et al.<br>Oberle<br>Yulkowski et al.<br>Yulkowski<br>Yulkowski et al.<br>Yulkowski<br>Nickel<br>Yulkowski et al. |                          |
| (58)                                 | <b>Field of Classification Search</b>   |  |   |  |                          |
|                                      | USPC ..... 49/25–28, 31, 138, 358, 359, 279, 280, 49/300, 302, 339, 340, 341<br>See application file for complete search history.   |  |   |  |                          |
| (56)                                 | <b>References Cited</b>   |  |   |  |                          |
|                                      | <b>U.S. PATENT DOCUMENTS</b>  |  |   |  |                          |
|                                      | 4,333,268 A 6/1982 Dumbeck  |  |   |  |                          |
|                                      | 4,562,664 A 1/1986 Kambic   |  |   |  |                          |
|                                      | 4,698,937 A 10/1987 Kombrekke et al.  |  |   |  |                          |
|                                      | 4,727,679 A * 3/1988 Kornbrekke et al. .... 49/138  |  |   |  |                          |
|                                      | 4,952,080 A 8/1990 Boiucaner et al.   |  |   |  |                          |
|                                      | 4,980,618 A 12/1990 Milnes et al.   |  |   |  |                          |
|                                      | 5,018,304 A 5/1991 Longoria   |  |   |  |                          |
|                                      | 5,040,331 A * 8/1991 Merendino et al. .... 49/25  |  |   |  |                          |
|                                      | 5,072,973 A 12/1991 Gudgel et al.   |  |   |  |                          |
|                                      | 5,250,765 A 10/1993 Mizuno et al.   |  |   |  |                          |
|                                      | 5,289,162 A 2/1994 McDaniel   |  |   |  |                          |
|                                      | 5,375,374 A 12/1994 Rohraff, Sr.  |  |   |  |                          |
|                                      | 5,392,562 A 2/1995 Carambula  |  |   |  |                          |
|                                      | 5,583,405 A 12/1996 Sai et al.  |  |   |  |                          |
|                                      | 5,770,934 A 6/1998 Theile   |  |   |  |                          |
|                                      | 5,813,171 A 9/1998 Piltingsrud  |  |   |  |                          |
|                                      | 5,878,530 A * 3/1999 Eccleston et al. .... 49/139   |  |   |  |                          |
|                                      | 5,913,763 A 6/1999 Beran et al.   |  |   |  |                          |
|                                      | 6,034,494 A 3/2000 Kitamine et al.  |  |   |  |                          |
|                                      | 6,049,287 A * 4/2000 Yulkowski ..... 340/693.12   |  |   |  |                          |
|                                      | 6,154,924 A * 12/2000 Woo ..... E05F 3/14<br>16/51  |  |   |  |                          |
|                                      | 6,183,023 B1 2/2001 Yulkowski   |  |   |  |                          |
|                                      | 6,223,469 B1 5/2001 Moll  |  |   |  |                          |
|                                      | 6,259,352 B1 * 7/2001 Yulkowski ..... E05B 47/00<br>340/5.7   |  |   |  |                          |
|                                      | 6,316,892 B1 11/2001 Valencia   |  |   |  |                          |
|                                      | 6,318,024 B1 11/2001 Krsnak et al.  |  |   |  |                          |
|                                      | 6,336,294 B1 1/2002 Kowalczyk et al.  |  |   |  |                          |
|                                      | 6,338,693 B1 * 1/2002 Scholten ..... E05F 15/614<br>477/7   |  |   |  |                          |
|                                      | 6,481,160 B1 11/2002 Kowalczyk  |  |   |  |                          |
|                                      | 6,553,238 B1 4/2003 Ginzel et al.   |  |   |  |                          |
|                                      | 6,553,717 B2 4/2003 St. John et al.   |  |   |  |                          |
|                                      | 6,588,153 B1 7/2003 Kowalczyk   |  |   |  |                          |
|                                      | 6,705,047 B2 * 3/2004 Yulkowski ..... E05F 3/22<br>16/65  |  |   |  |                          |
|                                      | 6,715,586 B1 4/2004 Shubin  |  |   |  |                          |
|                                      | 6,724,304 B2 4/2004 Risi  |  |   |  |                          |
|                                      | 6,751,909 B2 6/2004 Ranaudo   |  |   |  |                          |
|                                      | 6,788,000 B2 9/2004 Appelberg et al.  |  |   |  |                          |
|                                      | 6,854,565 B2 2/2005 Peralaet et al.   |  |   |  |                          |
|                                      | 6,891,479 B1 5/2005 Eccleston   |  |   |  |                          |
|                                      | 6,967,451 B2 * 11/2005 Miyauchi ..... 318/443   |  |   |  |                          |
|                                      | 6,970,085 B2 * 11/2005 Okabe et al. .... 340/545.6  |  |   |  |                          |
|                                      | 6,988,594 B2 1/2006 Deplazes et al.   |  |   |  |                          |
|                                      |   |  |   | <b>OTHER PUBLICATIONS</b>  |                          |
|                                      |   |  |   | 4 Pages, May 8, 2012, U.S. Appl. No. 12/416,622.   |                          |
|                                      |   |  |   | 3 Pages, Jan. 30, 2012, U.S. Appl. No. 12/416,622.   |                          |
|                                      |   |  |   | 19 Pages, Sep. 16, 2011, U.S. Appl. No. 12/416,622.  |                          |
|                                      |   |  |   | 5 Pages, Jul. 25, 2011, U.S. Appl. No. 12/416,622.   |                          |
|                                      |   |  |   | 11 Pages, Apr. 20, 2012, U.S. Appl. No. 12/416,622.  |                          |
|                                      |   |  |   | 4 Pages, Oct. 23, 2012, U.S. Appl. No. 12/719,954.   |                          |
|                                      |   |  |   | 23 Pages, Jul. 5, 2012, U.S. Appl. No. 12/719,954.   |                          |
|                                      |   |  |   | 3 Pages, Jun. 5, 2012, U.S. Appl. No. 12/719,954.  |                          |
|                                      |   |  |   | 8 Pages, Oct. 4, 2011, PCT/US2010/027423.  |                          |
|                                      |   |  |   | 4 Pages, Jun. 18, 2010, PCT/US2010/027423.   |                          |
|                                      |   |  |   | 8 Pages, Feb. 2, 2012, PCT/US2010/042286.  |                          |
|                                      |   |  |   | 4 Pages, Apr. 13, 2011, PCT/US2010/042286.   |                          |
|                                      |   |  |   | U.S. Appl. No. 12/719,954, filed Mar. 9, 2010.   |                          |
|                                      |   |  |   | U.S. Appl. No. 12/837,194, filed Jul. 15, 2010.  |                          |
|                                      |   |  |   | 20 Pages, Jan. 28, 2013, U.S. Appl. No. 12/837,194.  |                          |
|                                      |   |  |   | 30 Pages, Feb. 14, 2013, U.S. Appl. No. 12/719,954.  |                          |
|                                      |   |  |   | 2 Pages, May 7, 2013, U.S. Appl. No. 12/719,954.   |                          |
|                                      |   |  |   | 10 Pages, Jul. 11, 2013, U.S. Appl. No. 12/719,954.  |                          |
|                                      |   |  |   | 3 Pages, Jul. 30, 2013, U.S. Appl. No. 12/719,954.   |                          |

(56)

**References Cited**

OTHER PUBLICATIONS

16 Pages, Aug. 27, 2013, U.S. Appl. No. 12/837,194.  
25 Pages, Oct. 3, 2013, U.S. Appl. No. 12/719,954.  
International Search Report dated Jun. 18, 2010 for PCT application  
No. PCT/US2010/027423.  
3 Pages, Jul. 24, 2014, U.S. Appl. No. 14/139,699.  
14 Pages, Sep. 2, 2014, U.S. Appl. No. 14/139,699.  
3 Pages, Oct. 16, 2014, U.S. Appl. No. 14/139,699.  
15 Pages, May 19, 2014, U.S. Appl. No. 14/139,699.  
12 Pages, May 29, 2014, U.S. Appl. No. 12/719,954.  
23 Pages, Feb. 9, 2016, U.S. Appl. No. 14/485,452.  
25 Pages, Feb. 11, 2016, U.S. Appl. No. 14/547,434.  
U.S. Appl. No. 14/920,432, filed Oct. 22, 2015.  
20 Pages, Jun. 16, 2016, U.S. Appl. No. 14/485,452.  
11 Pages, Sep. 8, 2016, U.S. Appl. No. 14/547,434.  
2 Pages, Sep. 20, 2016, U.S. Appl. No. 14/547,434.  
3 Pages, Dec. 2, 2016, U.S. Appl. No. 14/547,434.  
33 Pages, Dec. 21, 2016, U.S. Appl. No. 14/485,452.  
U.S. Appl. No. 15/389,086, filed Dec. 22, 2016.  
35 Pages, Jul. 20, 2017, U.S. Appl. No. 14/485,452.  
19 Pages, Mar. 5, 2018, U.S. Appl. No. 14/920,432.  
5 Pages, Mar. 14, 2018, U.S. Appl. No. 15/389,086.  
6 Pages, Mar. 28, 2018, U.S. Appl. No. 15/389,086.  
23 Pages, Nov. 21, 2017, U.S. Appl. No. 14/920,432.

\* cited by examiner

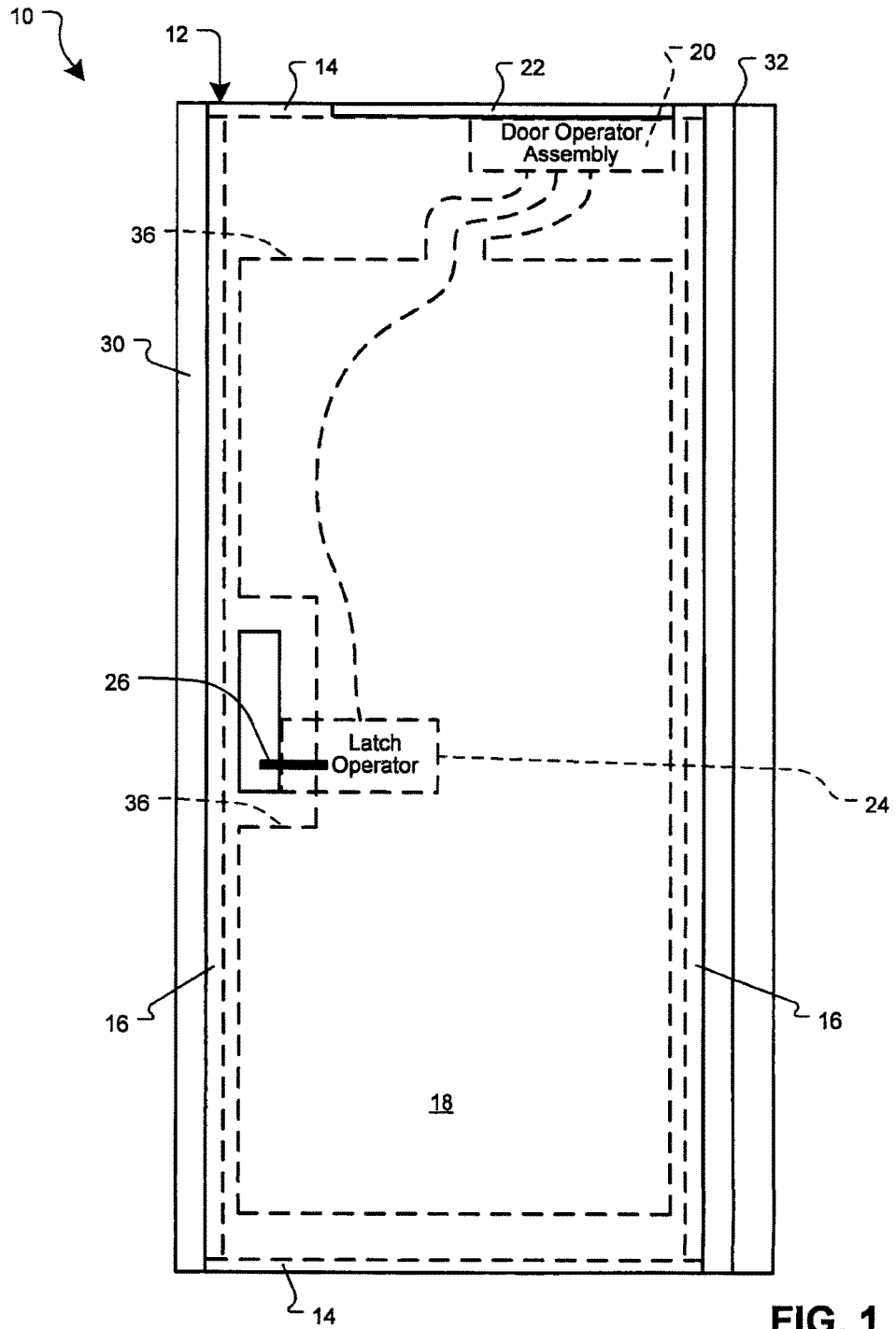

**FIG. 1**

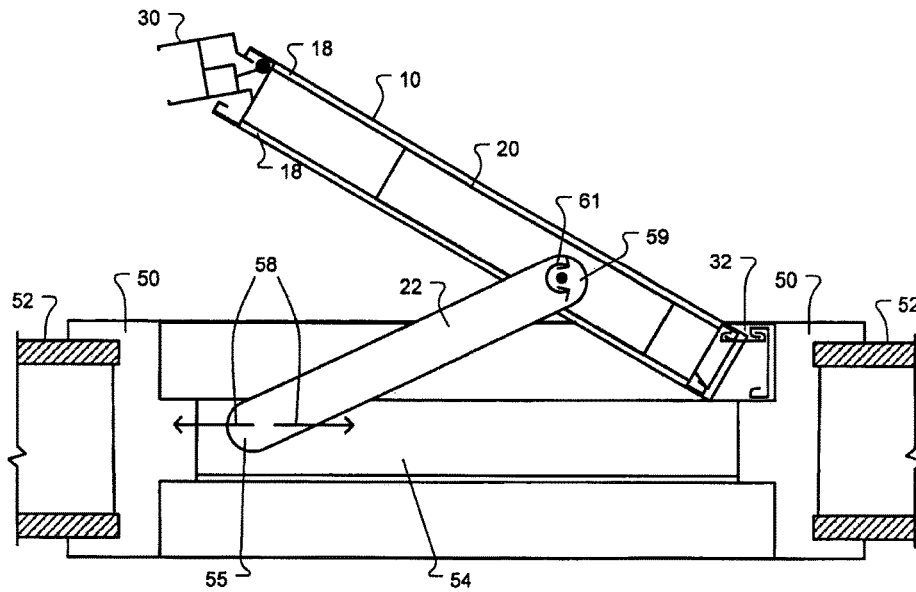

**FIG. 2**

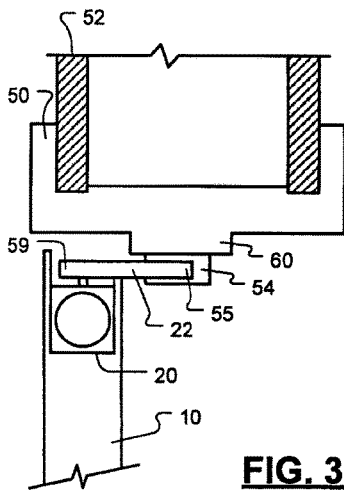

**FIG. 3**

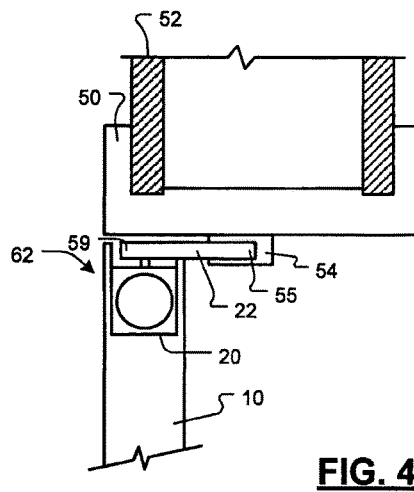

**FIG. 4**

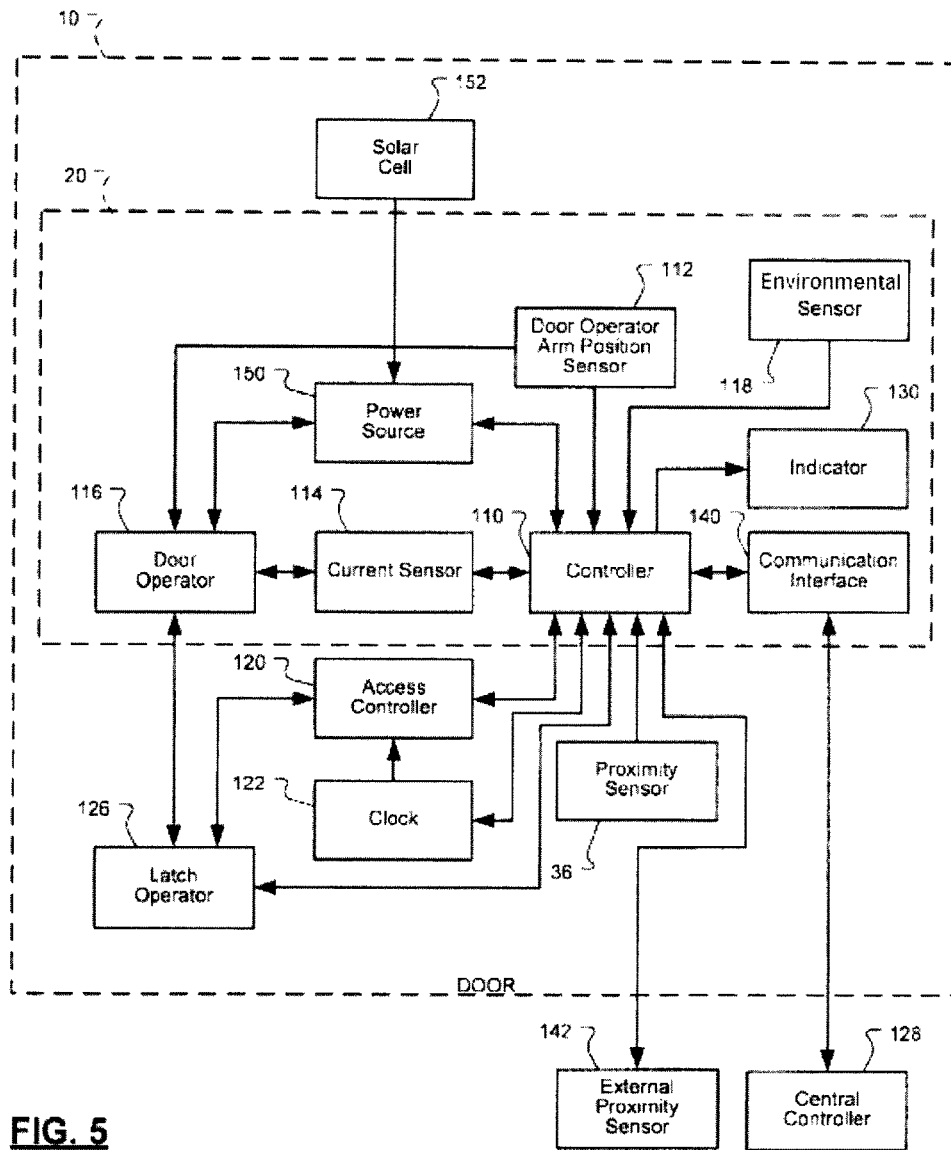
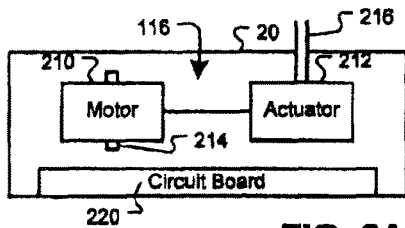
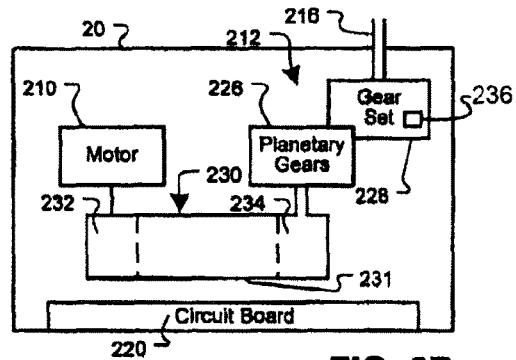

FIG. 5



**FIG. 6A**



**FIG. 6B**

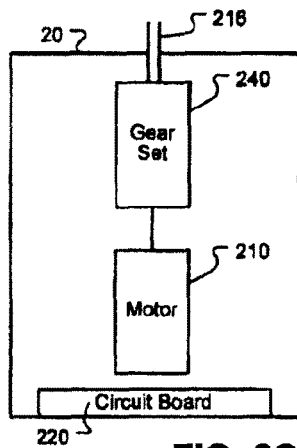

**FIG. 6C**

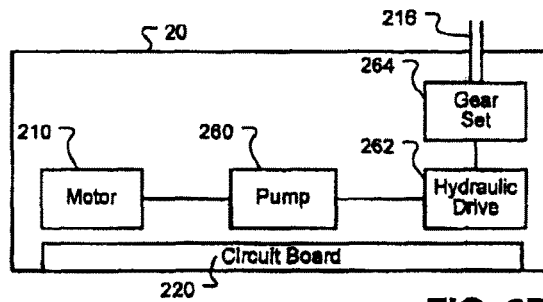

**FIG. 6D**

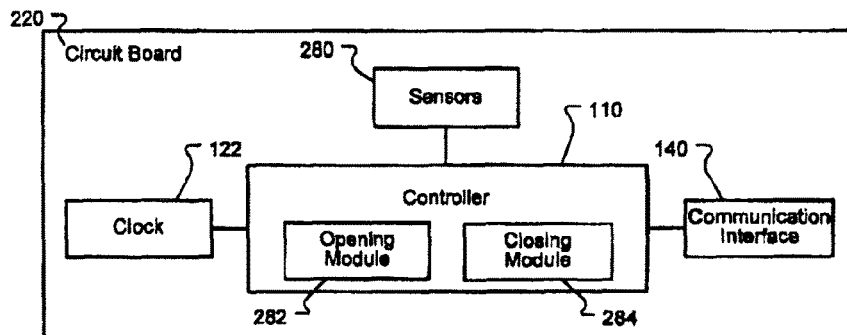

**FIG. 7**

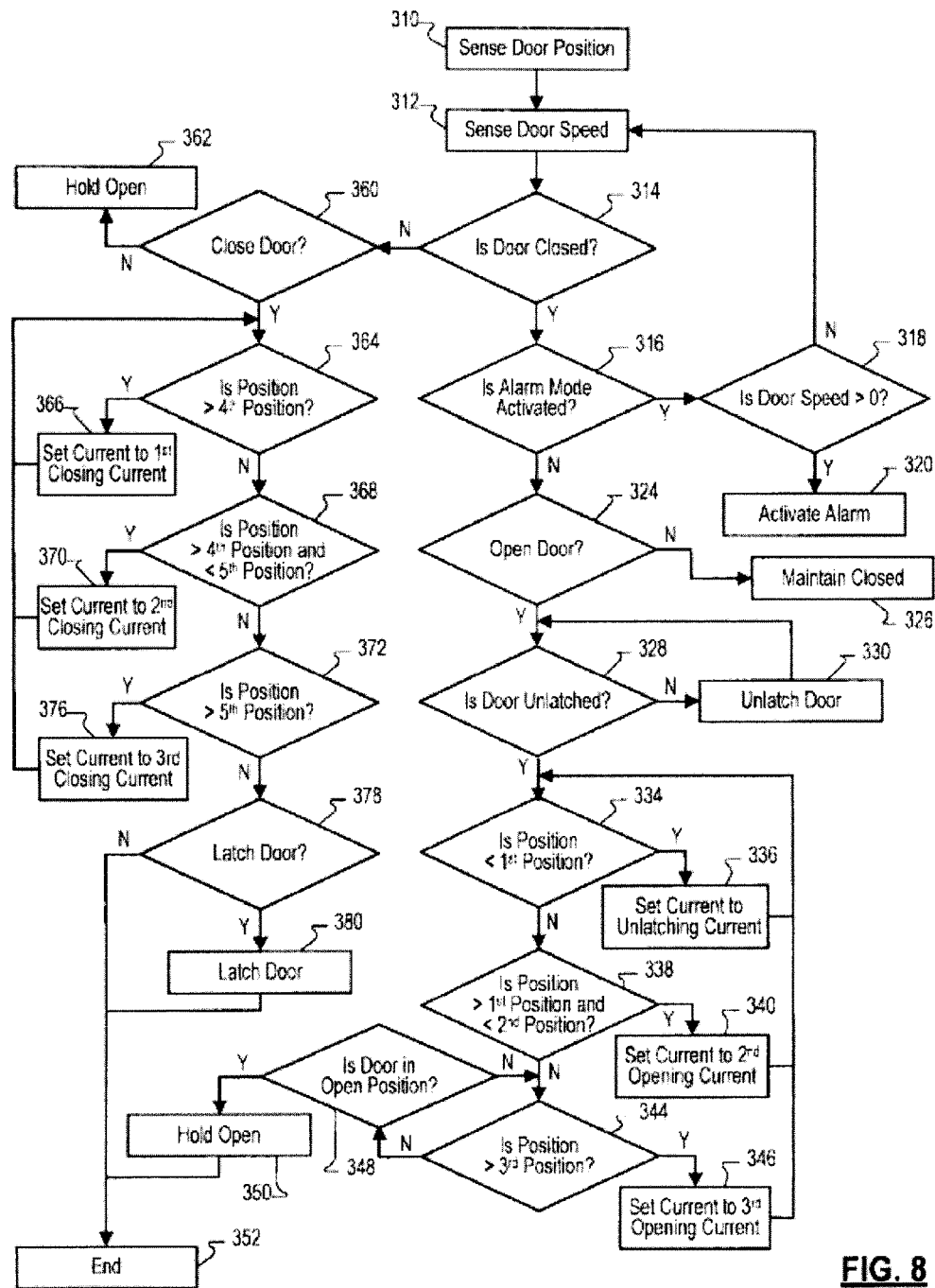
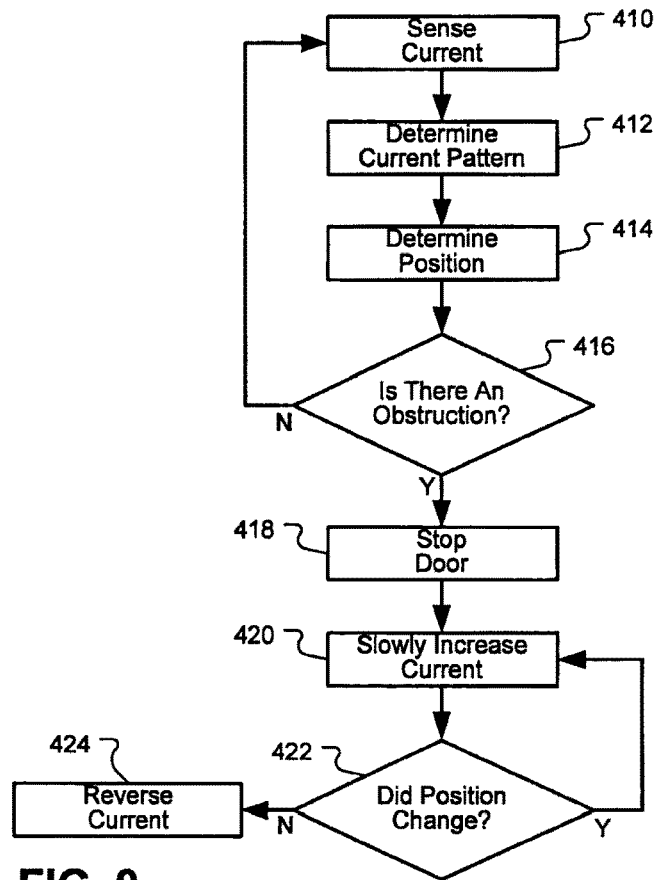
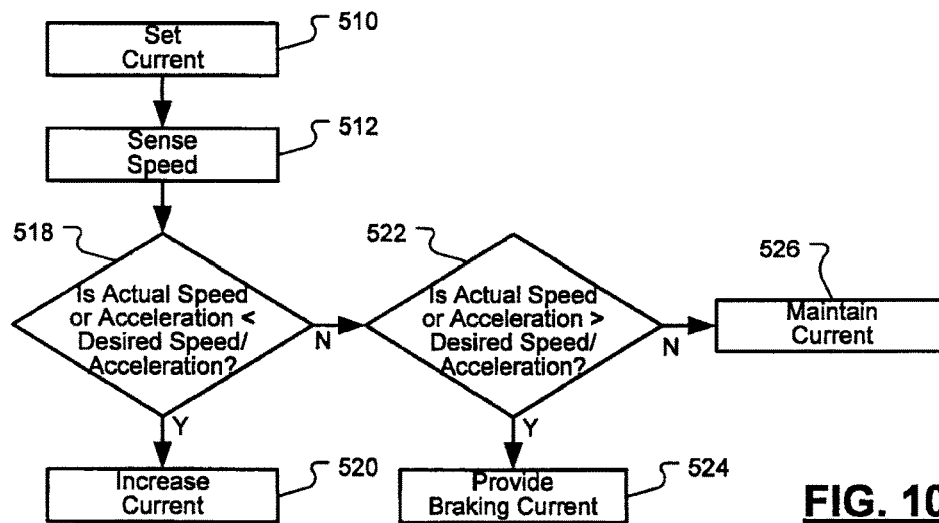

FIG. 8





**FIG. 9**



**FIG. 10**

1

## CONCEALED ELECTRICAL DOOR OPERATOR

### CROSS-REFERENCE TO RELATED APPLICATIONS

This application is a continuation of application Ser. No. 12/416,622, now U.S. Pat. No. 8,261,491, which claims the benefit of U.S. Provisional Application No. 61/041,696, filed on Apr. 2, 2008 and 61/054,952, filed on May 21, 2008. The entire disclosures of each of the above applications are incorporated herein by reference.

### FIELD

The present disclosure is related to door operators and, more specifically, to electrically-operated door operators.

### BACKGROUND

The background description provided herein is for the purpose of generally presenting the context of the disclosure. Work of the presently named inventors, to the extent it is described in this background section, as well as aspects of the description that may not otherwise qualify as prior art at the time of filing, are neither expressly nor impliedly admitted as prior art against the present disclosure.

Installing doors into buildings under construction typically requires the assistance of various tradesmen. For example, for one opening, tradesmen such as carpenters, painters, glaziers, electricians, and drywallers are required to complete the installation of the door. Other tradesmen may also be used for the installation of the door. The number of tradesmen increases when the door has security or other specialty items incorporated near the door opening. Reducing the number of tradesmen will reduce the overall cost of the door when installation is included. Also, a reduction in human factors may also be reduced.

Door operators are typically designed around the concept of a return spring capable of exerting latching pressure with a spring alone. For example, many return springs provide about 15 lbs. of latching pressure using a spring. A motor large enough to overcome the spring pressure must be provided to operator a door operator. A door operator is capable of moving a door from an open position to a closed position, as well as from a closed position to an open position. Because of the size of the spring and the motor, a box that is approximately 6"×6"×36" is mounted, in plain view, over the door opening to house the motor and spring. Providing such door hardware in plain view may reduce the aesthetic appeal of the opening.

### SUMMARY

The present disclosure provides a door operator assembly that does not include a return spring. Further, the electrical door operator is concealed within the door to provide a more aesthetically-pleasing door assembly.

In one aspect of the invention, a door operator includes a first door skin, a second door skin spaced apart from the first door skin and a door operator disposed between the first door skin and the second door skin. An arm extends from the door operator. The door operator includes a motor moving the arm to move the door between a closed position and an open position and between the open position and the closed position. A current sensor generates a current signal corresponding to the current to the motor. A position sensor in

2

communication with the door arm generates a position signal corresponding to the position of the door relative to the frame. A controller communicates with the sensor and the motor. The controller controls a motor current to the motor in response to the current signal and the position signal.

Further areas of applicability of the present disclosure will become apparent from the detailed description provided hereinafter. It should be understood that the detailed description and specific examples are intended for purposes of illustration only and are not intended to limit the scope of the disclosure.

### BRIEF DESCRIPTION OF THE DRAWINGS

The present disclosure will become more fully understood from the detailed description and the accompanying drawings, wherein:

FIG. 1 is a front elevational view of a door having a door operator assembly according to the present disclosure;

FIG. 2 is a top view of the door and door operator assembly of FIG. 1;

FIG. 3 is a side cut-away view of a door operator assembly for use in a retrofit situation;

FIG. 4 is side cut-away view of a door with an originally-fitted closer;

FIG. 5 is a block diagrammatic view of a door system according to the present disclosure;

FIG. 6A is a simplified block diagrammatic view of the motor and actuator of a door operator assembly;

FIG. 6B is an alternative simplified block diagrammatic view of the door operator assembly;

FIG. 6C is another alternative simplified block diagrammatic view of the door operator assembly according to the present disclosure;

FIG. 6D is yet another alternative simplified block diagrammatic view of the door operator assembly operated under the control of a motor and hydraulics;

FIG. 7 is a simplified block diagrammatic view of a circuit board for use in the door operator assembly;

FIG. 8 is a flow chart showing a method of operating the door operator assembly of the present disclosure;

FIG. 9 is a flow chart showing a method for controlling the operating current of the door in the present disclosure; and

FIG. 10 is a flow chart showing a method for setting and changing the operating current of the door.

### DETAILED DESCRIPTION

The following description is merely exemplary in nature and is in no way intended to limit the disclosure, its application, or uses. For purposes of clarity, the same reference numbers will be used in the drawings to identify similar elements. As used herein, the phrase at least one of A, B, and C should be construed to mean a logical (A or B or C), using a non-exclusive logical or. It should be understood that steps within a method may be executed in different order without altering the principles of the present disclosure.

As used herein, the term module refers to an Application Specific Integrated Circuit (ASIC), an electronic circuit, a processor (shared, dedicated, or group) and memory that execute one or more software or firmware programs, a combinational logic circuit, and/or other suitable components that provide the described functionality.

Referring now to FIG. 1, the present disclosure us set forth with respect to a door 10. The door 10 has a frame 12 that comprises horizontal stiles 14 and vertical stiles 16. The horizontal stiles 14 and vertical stiles 16 may be formed of a variety of materials, including wood, metal or a composite material.

The door 10 has a pair of outer faces 18, only one of which is illustrated in FIG. 1. The outer faces 18 may be referred to as “door skins.” The outer faces 18 may comprise various materials, including metal, wood and composite materials. The interior of the door 10 between pieces of the door frame 12 and the door skins 18 may be filled with various materials, including, but not limited to, spacers and fire resistant materials, depending on the type of door.

The door 10 may also include a door operator assembly 20. The door operator assembly 20 is disposed within the door 10 between the door skins 18. An arm 22 extending from the door operator assembly 20 may be used to position the door 10 and move the door into the desired position. The arm 22 may extend from the door operator to the door frame or to a track on the wall adjacent to the door frame. A latch operator 24 may also be disposed within the door skin 18. The latch operator 24 is associated with a door handle 26 that latches and unlatches the door. The latch operator 24 may be an electrically-operated latch operator, such as a motor or solenoid. The latch operator 24 may be in communication with the door operator assembly 20 and may operate under the control of the door operator assembly 20. (Details of the operation of the door operator assembly 20 and the latch operator 24 will be provided below.) The latch operator 24 may be a mechanical operator that is electrically locked or operated in response to sensing the movement of the door handle 26. One example of a mechanical latch operator is a panic bar. The latch operator 24 may be in communication with a latch mechanism 30 that is used for latching the door 10 within an external frame, as described below. A hinge 32 is used for rotating the door 10 within the external frame. Both the latch mechanism 30 and the hinge 32 may extend vertically along the entire edge of the door 10.

A proximity sensor 36, such as an antenna, may also be incorporated within the door 10. By providing the proximity sensor 36 within the door 10, the aesthetic appeal of the door is maintained. The proximity sensor 36 may sense the approach of an object or person and the speed of an object or person, and allow the door operator assembly 20 to operate. The proximity sensor 36 is in communication with the door operator assembly 20.

Referring now to FIG. 2, the door 10 is illustrated within an external door frame 50. The door frame 50 fastens the door 10 to a wall 52. The hinge 32 allows the door 10 to pivot about an axis within the frame 50. The door frame 50 may include or have an additional track 54 that allows a first end 55 of the operator arm 22 to slide therein in the direction indicated by arrows 58. As the position of the arm 22 rotates (as indicated by arrow 61) at a second end 59 to change the position of the door 10. The arm 22 is ultimately operated by motor and gear components within the door operator assembly 20, as will be further described below. Latch mechanism 30 engages the door frame 50 or another door in a double-door application.

Referring now to FIG. 3, a side cut-away view of a door 10 is shown, illustrating a door operator assembly 20 having the arm 22 attached thereto. The arm 22 may be attached to a motor within door operator assembly 20, as will be described below. The first end 55 of arm 22 slides within the track 54 associated with a door frame 50. The track 54 may

be referred to as a “concealed track” or “U-shaped” since only one end of the channel forming the track is open. That is, the track 54 may have a top side and a bottom side, and one of the sides opened to receive the arm 22. A stop 60 is integrally-formed with the door frame 50. The door 10 rests against the stop 60 in a closed position. The configuration of FIG. 3 is suitable for retrofitted doors in which the track 54 is added to the stop 60 and the door 10 then assembled within the door frame 50 to receive the arm 22.

Referring now to FIG. 4, a new construction type door assembly 62 is illustrated in which the track 54 is integrally formed with or attached to the top of the door frame 50 without a stop 60, as illustrated in FIG. 3. As the door 10 opens and closes under the influence of the door operator assembly 20, the first second end 55 of the arm 22 remains within the track 54.

Referring now to FIG. 5, the door 10 and the door operator assembly 20 are illustrated in further detail. The door operator assembly 20 includes a controller 110. The controller 110 may, for example, be a microprocessor-based controller. The controller 110 may be used to control various actions or outputs based upon various inputs.

The controller 110 may receive an input from a door operator arm position sensor 112. The door operator arm position sensor 112 generates a signal corresponding to the angular position of the operator arm 22. The angular position may be the position relative to the door 10. As the door 10 opens, the angular position signal corresponds to a larger angle than when the door is in a closed position. In a closed position, the angular position may be about zero. Various types of sensors may act as the position sensor 112, including a resistive sensor, a Hall Effect sensor, a pulse-counting sensor or an accelerometer that counts the amount of angular pulse signals from a door operator. Various types of sensors may be used.

The controller 110 may also be in communication with a current sensor 114. The current sensor 114 generates a current signal corresponding with the amount of current being applied to a door operator 116. The controller 110 may control a door operator 116. The door operator 116 may be various types of door operators, as will be described below. The door operator 116 may, for example, be a motor, a motor with a hydraulic pump or a pump with a plurality of gears, such as a rack gear or the like. By monitoring the current within the current sensor 114, the controller 110 can provide more or less opening force, change the velocity of the door opening or closing, or change the acceleration of the door opening or closing.

The controller 110 may also receive environmental signals from an environmental sensor 118. The environmental sensor 118 may be one sensor or a plurality of sensors that sense the environmental conditions around the door 10. One example of an environmental sensor 118 is a smoke detector that generates a smoke signal in response to a smoke condition. The environmental sensor 118 may also be a temperature sensor that senses the temperature around the door 10. The environmental sensor 118 may also be a toxic agent sensor that generates a toxic agent signal in the presence of toxic agents. Various types of toxic agents may be sensed, including, for example, radiation. Light levels may also be sensed by the environmental sensor 118. That is, the environmental sensor 118 may be a light sensor that generates a light signal corresponding to the amount of ambient light within an area around the door 10.

The controller 110 may also be in communication with an access controller 120. The access controller 120 may provide access for latching and unlatching the door through a

latch operator **126**. The access controller **120** may be a PIN pad, a fingerprint recognition system, a voice recognition system, a retina recognition system, or various combinations of the above. The access controller **120** may also be a card reader or the like. The access controller **120** may also be in communication with a clock **122** that records the time of various entries and exits through the door **10**. In conjunction with the access controller **120**, specific persons may be tracked based upon entry using the access controller **120**. The access controller **120** may also monitor and track attendance of various assets and the movement of the access or attendance of various persons or access within a building. The access controller **120** and clock **122**, in combination, may also unlock and lock various doors of a building based upon the calendar within the clock and the time associated with the clock.

The controller **110** may also control a latch operator **126**. The latch operator **126** may be a mechanical-based or electrical-based latch operator. The latch operator **126** may be used to lock the door **10** based upon inputs from the clock **122** or other inputs such as those from a central controller **128**. The latch operator **126** may allow the latch to be unlatched without the intervention of a person. By unlatching the door **10**, the latch operator **126** may then be easily moved by the motor associated with the door operator **116** into the desired position.

The proximity sensor **36** may also be an input to the controller **110**. The proximity sensor **36** may be one of a variety of sensors, such as the antenna illustrated in FIG. 1. Other types of proximity sensors **36** may be included within the door **10** and outside the door. For example, the proximity sensor **36** may be a motion detector that can gauge the speed of an approaching person or object and open the door **10** corresponding to the speed of the approaching person or object. On example of a suitable use is to sense the speed of an approaching gurney in a hospital environment. The proximity sensor **36** may also be a wall switch that activates door operator **116**, or other type of sensing device, such as a floor-mounted pad sensor. The proximity sensor **36** may also generate a signal to the controller **110** that, in response to the proximity sensor **36**, unlatches the latch through the latch operator **126**. Thus, a latch open signal may be generated by the controller **110** to unlatch the latch based upon a proximity signal corresponding to a person or object in proximity of the proximity sensor **36**. The latch operator **126** may also generate a latch completion signal to signal the controller **110** that opening the door **10** is enabled since the latch is open.

The controller **110** may also be communication with an indicator **130**. The indicator **130** may be an audible indicator, such as a buzzer, beeper or bell, or a visual indicator, such as a light-emitting diode, a display or a light. Audible signals, visual signals or both may be used in a particular system. The indicator **130** may generate an indicator in response to an alarm. By knowing that a particular door should not be opening and when the arm position sensor **112** generates a signal corresponding to the opening of the door during a guarded time period, the indicator **130** may generate an indicator corresponding to an alarm.

The controller **110** may also be in communication with a communication interface **140**. The communication interface **140** may communicate with the central controller **128** or other door controllers of a building. The communication interface **140** generates signals in the proper format and potentially with encryption to the central controller **128**. The controller **110** may communicate alarm signals to the central controller **128** through the communication interface **140**.

The central controller **128** may also generate control signals to the controller **110** to change various time periods associated with the door **10**, such as lock-down times, door-opening times, speeds and accelerations.

An external proximity sensor **142** may also be in communication with the controller **110**. The external proximity sensor **142** may be a wall-mounted switch or motion-detecting device that communicates a proximity sensor signal to the controller **110**.

A power source **150** may be in communication with the door operator assembly **20**. The power source **150** may, for example, be in communication with the door operator **116** and the controller **110**. Other devices within the door **10** may be in communication with the power source **150**. The power source **150** may be a battery that is used to operate the door operator assembly **20**. The power source **150** may be located between the door skins **18** illustrated in FIG. 2 within the door **10**. The power source **150** may be a rechargeable power source that is recharged by a solar cell **152**. The power source **150** may also be easily removable so it can be readily replaced.

FIGS. 6A-6D provide alternative embodiments to the layout within the door cavity.

Referring now to FIG. 6A, the door operator assembly **20** is illustrated with a high-level blocked diagrammatic view. In this embodiment, the door operator **116** may comprise a motor **210** and an actuator **212**. The motor **210** may have a vertical axis **214** oriented in a vertical direction. The actuator **212** may comprise gears and the like. The actuator **212** may comprise various types of gears, including planetary gears, worm gears, spur gears, and the like. The actuator **212** has a shaft **216** that is rotatably coupled to the arm **22** of FIGS. 1 and 2. Each of the embodiments below have the shaft **216** rotatably coupled to the arm **22**.

A circuit board **220** may be incorporated within the door operator assembly **20**. The circuit board **220** may house the controller and various other components, as described below. Sensors may also be disposed on the circuit board **220**. The circuit board **220** may comprise one circuit board or multiple circuit boards that are arranged to fit between the outer skins illustrated in FIG. 2 of the door. Each of the embodiments below may include the circuit board **220**.

Referring now to FIG. 6B, the actuator **212** of FIG. 6A may include planetary gears **226** and a secondary gear set **228**. The secondary gear set **228** may comprise spur gears **236** or the like. The motor **210** may be coupled to the planetary gears **226** using a belt drive **230**. A belt **231** extends from a first gear **232** coupled to the motor **210** and a second gear **234** coupled to the planetary gears **226**.

Referring now to FIG. 6C, the motor **210** is oriented axially with a gear set **240**. The gear set **240** is in communication with the operator arm **22** (not illustrated).

Referring now to FIG. 6D, the motor **210** is used to drive a pump **260**. The pump **260** is in fluid communication with a hydraulic drive **262**. By increasing the speed of the motor **210**, various pressures of hydraulic fluid may be provided to the hydraulic drive **262**. A gear **264**, which may be different or similar to the gear sets **240**, **228** described above, may couple the hydraulic drive **262** to the arm **22**.

In each of the embodiments illustrated in FIGS. 6A-6D, the motor **210** and actuator are sized to be fully received between the door skins of the door **10**. The gears are sized and positioned to convert the rotary motion of the motor **210** into motion of the arm **22**, which in turn opens or closes the door **10**.

Referring now to FIG. 7, the circuit board **220** of FIGS. 6A-6D is illustrated. Various components may be mounted

on or coupled to the circuit board 220. Various sensors are illustrated with reference numeral 280. The various sensors 280 may be the sensors illustrated in FIG. 5. At least some of the sensors 280 may be mounted directly on this circuit board 220.

The controller 110 may include an opening module 282. The opening module 282, based upon the various sensors 280, may control the opening position, opening speed and opening acceleration of the door relative to the door frame. A closing module 284 may also be provided within the controller 110. The closing module 284 may control the closing position, closing speed and closing acceleration of the door 10 of the controller 110. Both the opening module 282 and the closing module 284 may have several regions defined for different speeds, accelerations and positions. For example, the opening module 282 may provide an unlatching force in a first range, which corresponds to providing a predetermined current to obtain a predetermined velocity of the door at a predetermined acceleration. Once the door is unlatched and opened greater than a first predetermined amount, the first door speed or acceleration may be adjusted by controlling the motor current to a second door speed or acceleration. When close to being open after a second predetermined door position, the door speed or acceleration may change. Of course, multiple regions corresponding to the position may be provided so that different speeds of the door may be provided. The closing module 284 may, likewise, have different speeds and velocities associated with various positions. Several regions may also be provided for the closing module 284. When the door is nearly closed, the velocity for latching may be maintained by increasing the current to the motor to overcome the stack pressure of the building. Also, both modules 282 and 284 may compensate for wind pressure in either direction. That is, a wind forcing the door open while the opening module 282 is opening the door may require a resistive current to resist the speed of the wind. Likewise, if the wind is against the opening direction, additional current may be required to maintain the desired velocity of the door. The clock 122 and communication interface 140 may also be incorporated onto circuit board 220.

Referring now to FIG. 8, one method of operating the door is set forth. In step 310, the position of the door is sensed by the door operator arm position sensor 112 illustrated in FIG. 5. In step 312, the speed of the door relative to the frame is sensed. As will be described below, the position and the speed of the door allows the controller to control the current to maintain desired speeds and positions. In step 314, it is determined whether the door is closed. If the door is closed, step 316 determines whether an alarm mode has been activated. In an alarm mode, the door should not open. If an alarm mode has been activated in step 316, step 318 determines the door speed. If the door speed is not greater than zero, then step 312 is again performed. In step 318, if the door speed is greater than zero, then an alarm is activated in step 320.

Referring back to step 316, if the alarm mode has not been activated, it is determined whether the door is desired to be opened in step 324. If the door is not desired to be opened, step 326 is performed. Step 326 maintains the door in a closed position.

In step 324, if the door is desired to be opened, it is determined whether the door has been unlatched. If the door has not been unlatched, the door may be unlatched in step 330. The unlatching of the door may be mechanically or electro-mechanically performed using the latch operator. If the door is unlatched, step 334 is performed. In step 334, it

is determined whether the position of the door is less than a first position. The position of the door is determined constantly throughout the process since the door is ever changing. When the door is less than the first position, the current is set to an unlatching current in step 336. If the position is not less than first position, it is determined whether the position is between a first position and a second position in step 338. If the current is between a first and a second position, step 340 sets the current to a second opening current. In step 338, if the position of the door is not between a first position and a second position, step 344 may be performed. Step 344 determines whether the position is greater than a third position, but less than a fully-opened position. If the position is between the third position and the fully-opened position, step 346 sets the current to a third operating current. If the position is not between the third position and the fully-opened position, step 348 determines whether the door is in the opened position. If the door is not in the opened position, step 344 is again performed. If the door is in the opened position, step 350 holds the door in the open position. Step 352 ends the process.

Steps 336, 340 and 346 illustrate various operating currents that are used that correspond to various positions of the door. Different currents may be used to obtain different speeds or accelerations, as will be set forth in FIG. 10. Although the three different door positions and the opened positions are set forth, various numbers of positions corresponding to different currents may be provided, including less than three positions, such as one current for the entire door swing or more than three intermediate positions.

Referring back to step 314, it is determined whether the door is desired to be closed in step 360. If the door is not desired to be closed in 360, step 362 holds the door open. It should be noted that the hold open current for the door in step 362 and step 350 above may be a relatively low current since a return spring is not provided in the present configuration. In step 364, it is determined whether the position of the door is greater than a fourth position. If the position is greater than a fourth position, the closing current may be set to a first closing current in step 366. In step 364, if the position is not greater than a fourth position, step 368 is performed. In step 368, it is determined whether the position is between a fourth position and a fifth position. If the position is between a fourth position and a fifth position, the current may be set to a second closing current in step 370. If the position is not between a fourth position and a fifth position, step 372 may be performed. In step 372, it is determined whether the position is greater than a fifth position. If the position is greater than a fifth position, step 376 is performed. If the position is not greater than a fifth position, step 378 may be performed. In step 378, it is determined whether or not the door is to be latched. If the door is not to be latched, the method ends in step 352. If the door is to be latched in step 378, the door is latched in step 380 and the process ends in step 352. The door may be mechanically or electro-mechanically latched in step 380.

Referring now to FIG. 9, during the entire operating process of FIG. 8, the current may be sensed. This is illustrated in step 410. In step 412, a current pattern may be determined. The current pattern may look at the current for a time preceding the last current reading. The current readings may be performed at regular intervals. In step 414, the position of the door may also be used to determine whether or not an obstruction is present. In step 416, an obstruction is determined. An obstruction may be determined by looking at the current pattern, the position of the door or both. If there is no obstruction, step 410 is again

performed. Examples of obstructions may include a person contacting the door, door latch or door hinge. For example, fingers in the door hinge or latch may be an obstruction.

In step 416, if there is an obstruction, the movement of the door is stopped in step 418. It should be noted that the detection of the obstruction may be performed when the door is both opening and closing. In step 420, the current is slowly increased. If the position does change in step 422, the current is continually increased. If the position does not change in step 422, the current is reversed in step 424 to back up the door position to a previous position.

Referring now to FIG. 10, the setting of the current in steps 336, 340, 346, 366, 370, and 376 of FIG. 8 are illustrated in further detail. Each of the steps 336, 340 and 346 may have similar elements and are, thus, described here in further detail. In step 510, the current is set as provided above in one of the steps, such as 336, 340 and 346. In step 512, the speed of the moving door is determined. In step 518, the actual speed of the door or the acceleration is compared to a desired speed or desired acceleration. It should be noted that the acceleration of the door may be determined by determining a change in the speed sensed in step 512. In step 518, if the actual speed or acceleration is less than a desired speed or acceleration, the current may be increased in step 520. This allows the actual speed or acceleration to be increased to the desired speed or acceleration. It should be noted that both the speed and the acceleration may be increased by increasing the current in step 520. If the actual speed or acceleration is not less than the desired speed or acceleration, step 522 is performed. In step 522, if the actual speed or acceleration is greater than the desired speed or acceleration, step 524 is performed. In step 524, a braking current is provided to prevent the door from going faster than the desired speed or acceleration. This may occur when someone or some force is pushing on the door. The force may include a person pushing on the door or wind. If the actual speed or acceleration is not greater than the desired speed or acceleration, the system is operating as it should and the current is maintained in step 526.

The broad teachings of the disclosure can be implemented in a variety of forms. Therefore, while this disclosure includes particular examples, the true scope of the disclosure should not be so limited since other modifications will become apparent to the skilled practitioner upon a study of the drawings, the specification, and the following claims.

What is claimed is:

1. A door assembly comprising:

a door, comprising

a frame, comprising horizontal stiles and vertical stiles;

a first door skin; and

a second door skin spaced apart from the first door skin;

a door operator entirely disposed between the horizontal stiles and the vertical stiles and between the first door skin and the second door skin, the door operator further comprises a gear set, and the gear set comprising planetary gears; and

an arm extending from the door operator,

wherein said door operator comprises:

a motor moving the arm to move the door between a closed position and an open position and between the open position and the closed position,

a current sensor generating a current signal corresponding to a current to the motor;

a position sensor generating a position signal corresponding to a position of the door relative to a door frame; and

a controller communicating with the current sensor, the position sensor and the motor, said controller controlling a motor current to the motor in response to the current signal and the position signal, wherein the controller generates a braking current when a speed of the door is greater than a desired speed of the door for a predetermined position of the door.

2. The door assembly as recited in claim 1 wherein the controller increases the motor current to obtain a predetermined movement speed.

3. The door assembly as recited in claim 1 wherein the controller changes the motor current based on the position signal.

4. The door assembly as recited in claim 1 wherein the controller changes the motor current based on the position signal at least three times between the open position and the closed position.

5. The door assembly as recited in claim 1 further comprising a latch mechanism coupled to the door and a latch operator in communication with the controller and the latch mechanism, said controller controlling the motor current in response to a latch operator signal from the latch operator.

6. The door assembly as recited in claim 5 wherein the latch operator is disposed within the door.

7. The door assembly as recited in claim 1 further comprising an access controller in communication with the controller, said access controller enabling opening of the door.

8. The door assembly as recited in claim 7 wherein the access controller is disposed at least partially within the door.

9. The door assembly as recited in claim 1 further comprising a proximity sensor disposed between the first door skin and the second door skin, said proximity sensor generating a proximity signal corresponding to an object approaching the door, said controller controlling the motor current in response to the proximity signal.

10. The door assembly as recited in claim 1 further comprising an environmental sensor in communication with the controller, said environmental sensor generating an environment signal.

11. The door assembly as recited in claim 10 wherein the environmental sensor comprises at least one of a smoke sensor, a toxic agent sensor, a light sensor or a heat sensor.

12. The door assembly as recited in claim 1 wherein the door operator comprises a power source disposed between the first door skin and the second door skin.

13. The door assembly as recited in claim 12 wherein the power source comprises a battery.

14. The door assembly as recited in claim 12 wherein the power source comprises a rechargeable battery.

15. The door assembly as recited in claim 1 wherein a first end of the arm is rotatably coupled to the door operator and a second end of the arm is slidably coupled within a channel coupled to the door frame.

16. A communication system comprising:

a central controller; and

the door assembly as recited in claim 1,

wherein the door assembly comprises a communication interface for communicating with the central controller.

17. The door assembly as recited in claim 1 further comprising a proximity sensor disposed on the first door skin generating a proximity signal corresponding to an object approaching the door.

18. The door assembly as recited in claim 1 wherein the gear set further comprises:

11

spur gears,  
a first gear coupled to the motor, and  
a second gear coupled to the planetary gears.

19. The door assembly as recited in claim 1 wherein the position sensor comprises an accelerometer.

20. A door assembly comprising:

a door, comprising

a frame, comprising horizontal stiles and vertical stiles;  
a first door skin; and

a second door skin spaced apart from the first door skin;

a door operator disposed between the horizontal stiles and the vertical stiles and between the first door skin and the second door skin; and

an arm extending from the door operator,

wherein said door operator comprises:

a motor moving the arm to move the door between a closed position and an open position and between the open position and the closed position,

a current sensor generating a current signal corresponding to a current to the motor;

12

a position sensor generating a position signal corresponding to a position of the door relative to a door frame; and

a controller communicating with the current sensor, the position sensor and the motor, said controller controlling a motor current to the motor in response to the current signal and the position signal, wherein the controller generates a braking current when a speed of the door is greater than a desired speed of the door for a predetermined position of the door.

21. The door assembly as recited in claim 20 further comprising a gear set and a belt drive in communication with the motor and the gear set, said gear set operating the door arm in response to movement of the belt drive.

22. The door assembly of claim 20, wherein the door operator further comprises a gear set comprising planetary gears.

\* \* \* \* \*