



(12) **United States Design Patent**  
**Markoski et al.**

(10) **Patent No.:** **US D827,572 S**  
(45) **Date of Patent:** **\*\* Sep. 4, 2018**

- (54) **FLEXIBLE FUEL GENERATOR**
- (71) Applicant: **INI Power Systems, Inc.**, Morrisville, NC (US)
- (72) Inventors: **Larry J. Markoski**, Raleigh, NC (US); **Timothy C. Simmons**, Durham, NC (US); **William K. Carpenter**, Warrenton, NC (US); **Nathan Thomas Spalding Maher**, Cary, NC (US)
- (73) Assignee: **INI Power Systems, Inc.**, Morrisville, NC (US)

- 2,503,490 A 4/1950 Robert
- 2,520,226 A 8/1950 Smith
- 2,986,135 A 5/1961 Clark et al.
- 2,995,127 A 8/1961 Orr
- 3,493,217 A 2/1970 Farley
- 3,593,023 A 7/1971 Dodson et al.
- 3,760,781 A 9/1973 Boldt

(Continued)

**FOREIGN PATENT DOCUMENTS**

- CA 2860584 11/2014
- CA 2865806 11/2014

(Continued)

**OTHER PUBLICATIONS**

Yamaha Generator Owners Manual EF1000iS, 51 pages, 2004.  
(Continued)

*Primary Examiner* — Derrick Holland  
(74) *Attorney, Agent, or Firm* — Evan Law Group LLC

- (\*\*) Term: **14 Years**
- (21) Appl. No.: **29/522,542**
- (22) Filed: **Mar. 31, 2015**
- (51) **LOC (11) Cl.** ..... **13-01**
- (52) **U.S. Cl.**  
USPC ..... **D13/112; D13/122**
- (58) **Field of Classification Search**  
USPC ..... D13/101, 110, 112, 113, 114, 116, 118, D13/122, 184, 199; D23/386, 395; 290/1 A, 1 R  
CPC ..... F02B 63/04; F02B 63/048; F02B 69/02; F02B 9/04; H02K 7/1815; H02J 7/32; Y02T 10/16; Y02T 10/20; Y02T 10/36  
See application file for complete search history.

(57) **CLAIM**

The ornamental design for a flexible fuel generator, as shown and described.

**DESCRIPTION**

FIG. 1 is a front elevation view of a flexible fuel generator showing our new design;  
FIG. 2 is a back elevation view thereof;  
FIG. 3 is a left side elevation view thereof;  
FIG. 4 is a right side elevation view thereof;  
FIG. 5 is a top plan view thereof;  
FIG. 6 is a bottom plan view thereof;  
FIG. 7 is a front, top, and left side perspective view thereof; and,  
FIG. 8 is a back, top, and left side perspective view thereof.  
The broken lines shown illustrate the portions of the claim that form no part of the claimed design.

(56) **References Cited**  
U.S. PATENT DOCUMENTS

- D10,647 S 4/1878 Kimberly
- 1,367,789 A 2/1921 Torres
- 1,467,620 A 9/1923 Lindsey
- 1,573,641 A 2/1926 Hunt
- 1,792,785 A 2/1931 Upton et al.
- 1,835,490 A 12/1931 Hesselman
- 2,211,690 A 8/1940 Edwards

**1 Claim, 8 Drawing Sheets**

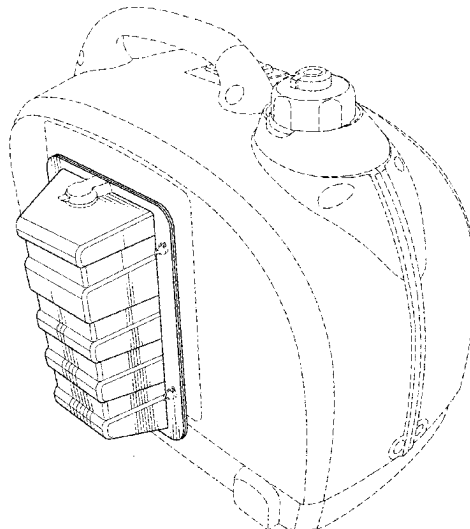

(56)

References Cited

U.S. PATENT DOCUMENTS

3,806,854	A	4/1974	Armstrong	7,574,993	B2	8/2009	Gillespie	
3,966,330	A	6/1976	Ridler et al.	7,603,983	B2	10/2009	Bahner	
3,980,065	A	9/1976	Nomura	7,690,336	B2	4/2010	Bowman et al.	
4,052,490	A	10/1977	Fedison	7,695,049	B2	4/2010	Colborne	
4,058,097	A	11/1977	Hutton	7,765,794	B2	8/2010	Alexander	
4,075,835	A	2/1978	Hattori	D625,774	S *	10/2010	Nirenberg	D23/211.1
4,104,994	A	8/1978	Phillips	7,849,680	B2	12/2010	Shaff et al.	
4,109,193	A	8/1978	Schultheis	7,893,658	B2	2/2011	Bhardwaj	
4,142,487	A	3/1979	Somraty	D633,443	S	3/2011	Wang et al.	
4,143,620	A	3/1979	Noguchi	8,061,121	B2	11/2011	Haugen	
4,150,545	A	4/1979	Yamazaki	D650,739	S	12/2011	Cai	
4,165,348	A	8/1979	Nakamura	8,100,093	B2	1/2012	Morgenstern	
4,196,701	A	4/1980	Tamura	D662,881	S	7/2012	He et al.	
4,221,206	A	9/1980	Haas	D680,555	S	4/2013	Craig	
4,276,864	A	7/1981	Waschkuttis	8,516,989	B2	8/2013	Schmidt	
4,284,944	A	8/1981	Iwanaga	8,567,354	B2	10/2013	Kealy et al.	
4,344,898	A	8/1982	Takada	8,601,772	B2	12/2013	Turpin et al.	
4,374,508	A	2/1983	Pena	8,657,264	B2	2/2014	Kin	
4,386,938	A	6/1983	Earle	8,810,053	B2	2/2014	Markoski	
4,433,548	A	2/1984	Hallstrom, Jr.	8,698,451	B2	4/2014	King et al.	
4,438,733	A	3/1984	Sasaki	D710,301	S	8/2014	Ferro	
4,470,386	A	9/1984	Okumura	D711,319	S	8/2014	Wilcox	
D276,515	S *	11/1984	Yaguchi	D712,834	S	9/2014	Munro	
4,489,680	A	12/1984	Spokas et al.	D733,052	S	6/2015	Markoski et al.	
4,491,118	A	1/1985	Woodridge	D736,932	S	8/2015	Nakagawa	
4,508,071	A	4/1985	Drenner	9,175,601	B2	11/2015	Markoski	
4,548,164	A	10/1985	Ylönen et al.	9,188,033	B2	11/2015	Markoski	
D282,252	S	1/1986	Yamaguchi	9,276,278	B2 *	3/2016	Adcock	C01B 3/04
4,595,841	A *	6/1986	Yaguchi	9,450,450	B2	9/2016	Markoski	
				D794,562	S	8/2017	Markoski et al.	
D289,033	S	3/1987	Makinson et al.	2001/0047777	A1	12/2001	Allen	
4,724,812	A	2/1988	Akagi	2002/0148221	A1	10/2002	Jagtoyen et al.	
4,878,475	A	11/1989	Birsa	2003/0141845	A1	7/2003	Krieger	
D305,880	S	2/1990	Ito	2004/0004356	A1	1/2004	Akimoto et al.	
4,936,280	A	6/1990	Langlois	2004/0025817	A1	2/2004	Uenoyama	
4,968,941	A	11/1990	Rogers	2004/0146754	A1 *	7/2004	Arthur	B01J 7/00 422/198
5,090,967	A	2/1992	Lindström	2004/0221828	A1	11/2004	Ries-Mueller et al.	
5,119,775	A	6/1992	Kokubo et al.	2006/0065216	A1	3/2006	Sugimoto	
5,162,662	A	11/1992	Nakayama	2007/0107693	A1	5/2007	Ohtsuji	
5,199,397	A	4/1993	Shelef et al.	2008/0007205	A1	1/2008	Thimm	
D340,565	S	10/1993	Klopfenstein	2009/0013965	A1	1/2009	Bahner	
5,444,378	A	8/1995	Rogers	2009/0171554	A1	7/2009	Yaguchi	
5,447,308	A	9/1995	Girard	2009/0314243	A1	12/2009	Schmidt et al.	
5,458,350	A	10/1995	Johnson et al.	2010/0019729	A1	1/2010	Kaita et al.	
5,460,149	A	10/1995	Tofel	2010/0030431	A1	2/2010	Potter	
5,533,489	A	7/1996	Socci et al.	2010/0072757	A1	3/2010	Kealy	
5,555,853	A	9/1996	Bowen et al.	2010/0170481	A1	7/2010	Walker	
5,566,745	A	10/1996	Hill et al.	2010/0192928	A1	8/2010	Yuasa	
D379,640	S	6/1997	Gilbert	2010/0201328	A1	8/2010	Monsive, Jr.	
5,794,601	A	8/1998	Pantone	2010/0258094	A1	10/2010	Hull	
D417,651	S	12/1999	Ohsumi	2010/0268438	A1	10/2010	Hiranuma	
D420,465	S	2/2000	Cascio	2010/0320774	A1	12/2010	Bindhammer	
6,100,599	A	8/2000	Kouchi et al.	2011/0099144	A1	4/2011	Levy	
6,112,635	A	9/2000	Cohen	2011/0114068	A1	5/2011	Habing et al.	
D437,825	S	2/2001	Imai	2011/0168128	A1	7/2011	Bradley et al.	
6,401,012	B1	6/2002	Aoki	2012/0012574	A1	1/2012	Vandrak et al.	
D472,164	S	3/2003	Newton	2012/0091790	A1	4/2012	Utsumi	
6,550,430	B2	4/2003	Gray	2012/0150359	A1	6/2012	Westergaard	
6,564,556	B2	5/2003	Ginter	2012/0247435	A1	10/2012	Veerathappa et al.	
6,581,375	B2	6/2003	Jagtoyen et al.	2012/0291420	A1	11/2012	Kim et al.	
D477,569	S	7/2003	Iwatate et al.	2013/0054060	A1	2/2013	Dupuy	
6,585,235	B2	7/2003	Pattullo	2013/0082517	A1	4/2013	Kawai	
6,698,404	B2	3/2004	Palkowitsh	2013/0085657	A1	4/2013	Bito	
6,739,289	B2	5/2004	Hiltner et al.	2013/0131966	A1	5/2013	Hirano	
6,843,236	B1	1/2005	Shetley	2013/0152898	A1	6/2013	Ki et al.	
6,886,648	B1	5/2005	Hata	2013/0158837	A1	6/2013	Jung et al.	
D518,771	S	4/2006	Xiao	2013/0168969	A1	7/2013	Markoski	
D520,948	S	5/2006	Xiao	2013/0221684	A1	8/2013	Markoski	
7,049,707	B2	5/2006	Wurtele	2014/0283771	A1	9/2014	Mukaide	
D532,748	S	11/2006	Disbennett et al.	2015/0014998	A1	1/2015	Markoski	
7,161,253	B2	1/2007	Sodemann et al.	2015/0034025	A1	2/2015	Markoski et al.	
7,183,746	B1	2/2007	Carter	2015/0134166	A1	5/2015	Aoki	
7,302,795	B2	12/2007	Vetrovec	2016/0084201	A1	3/2016	Markoski et al.	
D594,819	S	6/2009	Yamamoto et al.	2016/0152144	A1	6/2016	Choi	
D597,485	S	8/2009	Ma	2016/0258352	A1	9/2016	Markoski	
				2016/0258387	A1	9/2016	Markoski	

(56) **References Cited**  
U.S. PATENT DOCUMENTS

2017/0054321 A1 2/2017 Markoski et al.  
2017/0130676 A1 5/2017 Markoski et al.

## FOREIGN PATENT DOCUMENTS

CN 200952429 Y 9/2007  
CN 201045307 4/2008  
CN 102104280 6/2011  
CN 201330438963.6 2/2014  
CN 201380014569.7 5/2015  
CN 201380014569.7 11/2015  
CN 201530380535.1 3/2016  
CN 201280070700.7 7/2016  
CN 201280070700.7 4/2017  
DE 10 2009 052 571 A1 5/2011  
EM 001440077 10/2015  
EP 0 999 359 5/2000  
EP 1 069 295 A2 1/2001  
EP 1 383 224 A1 1/2004  
EP 1 505 709 A2 2/2005  
EP 2 327 864 6/2011  
EP 12821085.3 9/2015  
EP 13709278.9 12/2015  
EP 12821085.3 1/2016  
EP 12821085.3 10/2016  
FR 2 815 486 4/2002  
FR 2 959 888 A1 11/2011  
FR 2 962 002 A1 12/2011  
GB 2 184075 A 6/1987  
GB 1302360.1 3/2013  
GB 1302360.1 8/2013  
GB 1302360.1 1/2014  
IL 233473 1/2015  
IN 256526 12/2013  
IN 276173 2/2016  
JP 64-32060 2/1989  
JP 2010-236301 9/1998  
JP 11-190220 7/1999  
JP 2001-27128 1/2001  
JP 2003-219573 7/2003  
JP 2003-293771 10/2003  
JP 2003-293788 10/2003  
JP 2004-245219 9/2004  
JP 2006-188980 7/2006  
JP 2008-54442 3/2008  
JP 2008/067496 3/2008  
JP 2008/67496 3/2008  
JP 2008-255831 10/2008  
JP 2010-20906 1/2010  
JP 2010-158129 7/2010  
JP 2011-120346 6/2011  
JP 2011-252407 12/2011  
JP 2012-7508 1/2012  
JP 2012-23825 2/2012  
JP 2012-34488 2/2012  
JP 2010-279107 12/2012  
JP 2014-559960 9/2015  
JP 2014-551271 12/2015  
JP 2014-559960 1/2016  
WO WO 95/26464 10/1995  
WO 1999/35389 7/1999  
WO 2010/068284 6/2010  
WO WO 11/015731 A1 2/2011  
WO 2011/070517 6/2011  
WO WO 2012/005021 1/2012  
WO WO 2012/011568 1/2012  
WO PCT/US2012/070849 3/2013  
WO PCT/US2012/071042 6/2013  
WO WO 13/103532 A1 7/2013  
WO WO 13/103542 A2 7/2013  
WO WO 13/130533 9/2013  
WO PCT/US13/27922 11/2013  
WO PCT/US13/27922 1/2014  
WO PCT/US2012/070849 7/2014  
WO PCT/US2012/071042 8/2014

WO PCT/US13/27922 9/2014  
WO PCT/US2015/050437 12/2015  
WO 2016/048752 3/2016

## OTHER PUBLICATIONS

Honda Owner's Manual Generator EU1000i, 92 pages, (2008).  
Options for Generators and Welders, located at [www.hondapowerequipment.com/pdf/Accessories/ml.repap44a.generators.pdf](http://www.hondapowerequipment.com/pdf/Accessories/ml.repap44a.generators.pdf), 15 pages, downloaded Oct. 1, 2011.  
Yamaha Inverter EF2000iS Specifications, located at [www.yamahamotor.com/outdoor/products/modelspecs\\_pdf.aspx?Is=outdoor&mid=626&showprevmodel=0](http://www.yamahamotor.com/outdoor/products/modelspecs_pdf.aspx?Is=outdoor&mid=626&showprevmodel=0), 1 page, downloaded Oct. 2011.  
Yamaha Inverter EF1000iS Specifications, located at [www.yamahamotor.com/outdoor/products/modelspecs\\_pdf.aspx?Is=outdoor&mid=442&showprevmodel=0](http://www.yamahamotor.com/outdoor/products/modelspecs_pdf.aspx?Is=outdoor&mid=442&showprevmodel=0), 1 page, downloaded Oct. 2011.  
Specification of Honda EU1000i, located at [www.hondapowerequipment.com/products/modeldetail.aspx?page=modeldetail&section=P2GG&modelname=EU1000i&modelid=EU1000IKN](http://www.hondapowerequipment.com/products/modeldetail.aspx?page=modeldetail&section=P2GG&modelname=EU1000i&modelid=EU1000IKN), 1 page, downloaded Oct. 1, 2011.  
Specification of Honda EU2000i, located at [www.hondapowerequipment.com/products/modeldetail.aspx?page=modeldetail&section=P2GG&modelname=EU2000i&modelid=EU2000IKN](http://www.hondapowerequipment.com/products/modeldetail.aspx?page=modeldetail&section=P2GG&modelname=EU2000i&modelid=EU2000IKN), 1 page, downloaded Oct. 1, 2011.  
Honda Power Equipment Decibels chart, located at [www.hondapowerequipment.com/images/dbchart.jpg](http://www.hondapowerequipment.com/images/dbchart.jpg), 1 page, downloaded Oct. 1, 2011.  
"Gasoline", Wikipedia, pp. 1-13, found at <http://en.wikipedia.org/wiki/gasoline>, printed on Dec. 4, 2012.  
"Petrol-paraffin engine", Wikipedia, pp. 1-2, found at [http://en.wikipedia.org/wiki/petrol-paraffin\\_engine](http://en.wikipedia.org/wiki/petrol-paraffin_engine), printed on Dec. 3, 2012.  
United Kingdom Search and Examination Report dated Mar. 27, 2013 for GB application No. GB1302360.1, 10 pages.  
International Search Report dated Mar. 15, 2013 for PCT application No. PCT/US/2012/070849.  
Translation of Japanese Office Action dated Feb. 12, 2015.  
Translation of Japanese Office Action dated Mar. 2, 2015.  
PCT Search Report dated Nov. 21, 2013 for PCT application No. PCT/US2013/027922.  
Jul. 30, 2015, U.S. Appl. No. 13/343,597.  
Sep. 16, 2015, U.S. Appl. No. 14/370,374.  
Sep. 30, 2015, U.S. Appl. No. 14/370,374.  
Oct. 14, 2015, U.S. Appl. No. 14/370,374.  
Nov. 4, 2015, U.S. Appl. No. 14/336,361.  
Jan. 27, 2016, U.S. Appl. No. 14/493,168.  
U.S. Appl. No. 14/875,369, filed Oct. 5, 2015.  
U.S. Appl. No. 14/875,441, filed Oct. 5, 2015.  
U.S. Appl. No. 14/933,859, filed Nov. 5, 2015.  
May, 23, 2016, U.S. Appl. No. 14/336,361.  
Aug. 10, 2016, U.S. Appl. No. 14/493,168.  
Aug. 11, 2016, U.S. Appl. No. 29/527,360.  
U.S. Appl. No. 15/248,617, filed Aug. 26, 2016.  
Invitation to Pay Additional Fees and Partial International Search Report dated Feb. 17, 2017 for PCT application No. PCT/US2016/059739.  
International Search Report and Written Opinion dated Apr. 11, 2017 for PCT application No. PCT/US2016/059739.  
Jun. 6, 2017, U.S. Appl. No. 14/493,168.  
Sep. 12, 2013, U.S. Appl. No. 13/343,597.  
Jan. 15, 2014, U.S. Appl. No. 13/343,597.  
Jan. 6, 2014, U.S. Appl. No. 13/408,903.  
Feb. 28, 2014, U.S. Appl. No. 13/408,903.  
Apr. 16, 2014, U.S. Appl. No. 13/408,903.  
Sep. 30, 2014, U.S. Appl. No. 13/343,597.  
Dec. 15, 2014, U.S. Appl. No. 29/449,784.  
Dec. 31, 2014, U.S. Appl. No. 14/370,374.  
Mar. 9, 2015, U.S. Appl. No. 29/449,784.  
Feb. 25, 2015, U.S. Appl. No. 14/370,374.  
May 5, 2015, U.S. Appl. No. 13/343,597.  
May 13, 2015, U.S. Appl. No. 14/370,374.  
U.S. Appl. No. 13/343,597, filed Jan. 4, 2012.  
U.S. Appl. No. 14/336,361, filed Jul. 21, 2014.

(56)

**References Cited**

OTHER PUBLICATIONS

U.S. Appl. No. 29/449,784, filed Mar. 15, 2013.  
U.S. Appl. No. 14/370,374, filed Dec. 20, 2012.  
U.S. Appl. No. 14/493,168, filed Sep. 22, 2014.  
U.S. Appl. No. 14/370,374, filed Jun. 16, 2015.  
U.S. Appl. No. 13/343,597, filed Jun. 22, 2015.  
U.S. Appl. No. 14/370,374, filed Jun. 26, 2015.  
International Search Report dated Dec. 15, 2015 for PCT application No. PCT/US2015/050437.  
"Choke Valve", Wikipedia, pp. 1-2, found at [http://en.wikipedia.org/wiki/Choke\\_valve](http://en.wikipedia.org/wiki/Choke_valve), printed on Nov. 2, 2016.  
"Electric heater under carb, EFE (Early Fuel Evaporation)", MPGResearch, found at [www.mpgresearch.com/groups/induction-and-exhaust/electric-heater-under-carb-efe-early-fuel-evaporation](http://www.mpgresearch.com/groups/induction-and-exhaust/electric-heater-under-carb-efe-early-fuel-evaporation), pp. 1-3, printed on Jun. 4, 2015.  
Product Description, "Carburetor Heater for 14RESL and 14RESAL Generators", found at [www.homedepot.com/p/KOHLER-Carburetor-Heater-for-14RESL-and-14RESAL-Generators-GM19462-KP1/203269638](http://www.homedepot.com/p/KOHLER-Carburetor-Heater-for-14RESL-and-14RESAL-Generators-GM19462-KP1/203269638), pp. 1-2, printed on Jun. 4, 2015.  
U.S. Appl. No. 14/875,369, filed Nov. 29, 2016.  
U.S. Appl. No. 14/493,168, filed Feb. 7, 2017.  
U.S. Appl. No. 29/527,360, filed Mar. 21, 2017.  
U.S. Appl. No. 29/527,360, filed Apr. 21, 2017.  
U.S. Appl. No. 14/875,369, filed May 1, 2017.  
U.S. Appl. No. 15/248,617, filed May 4, 2017.  
U.S. Appl. No. 14/933,859, filed May 5, 2017.

\* cited by examiner

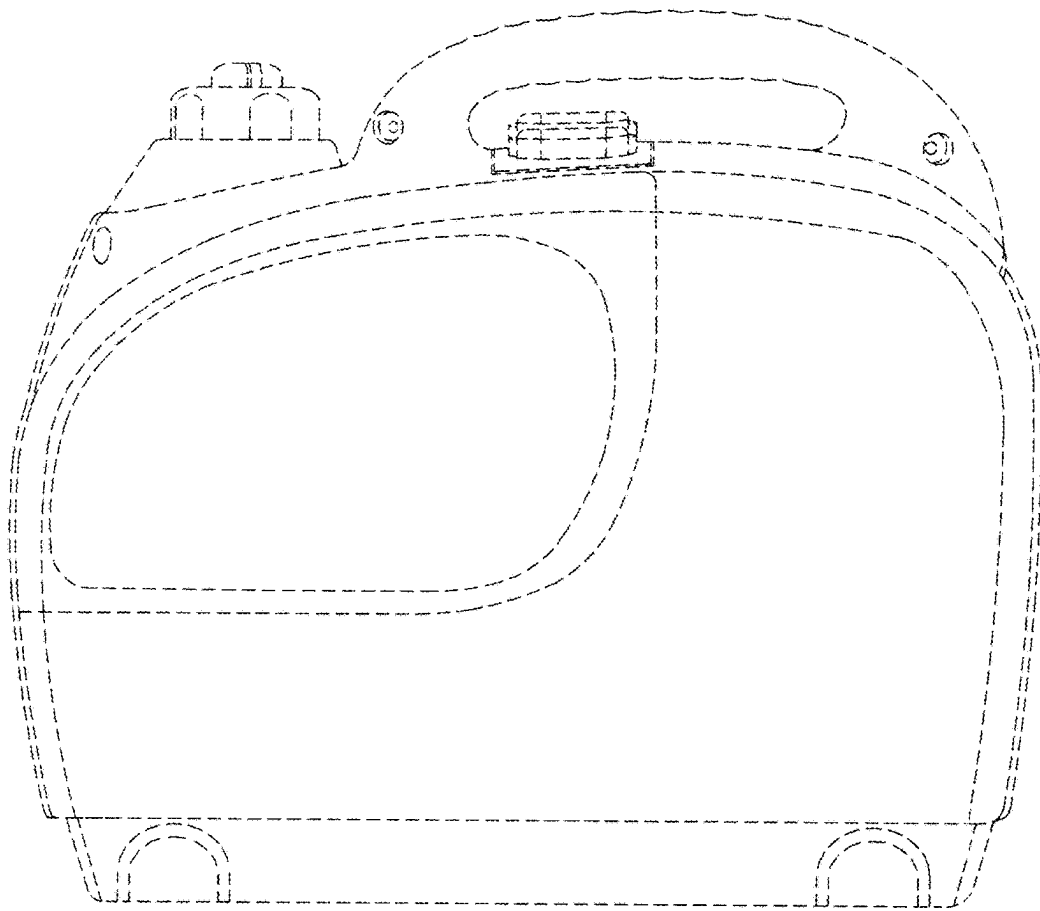

**FIG. 1**

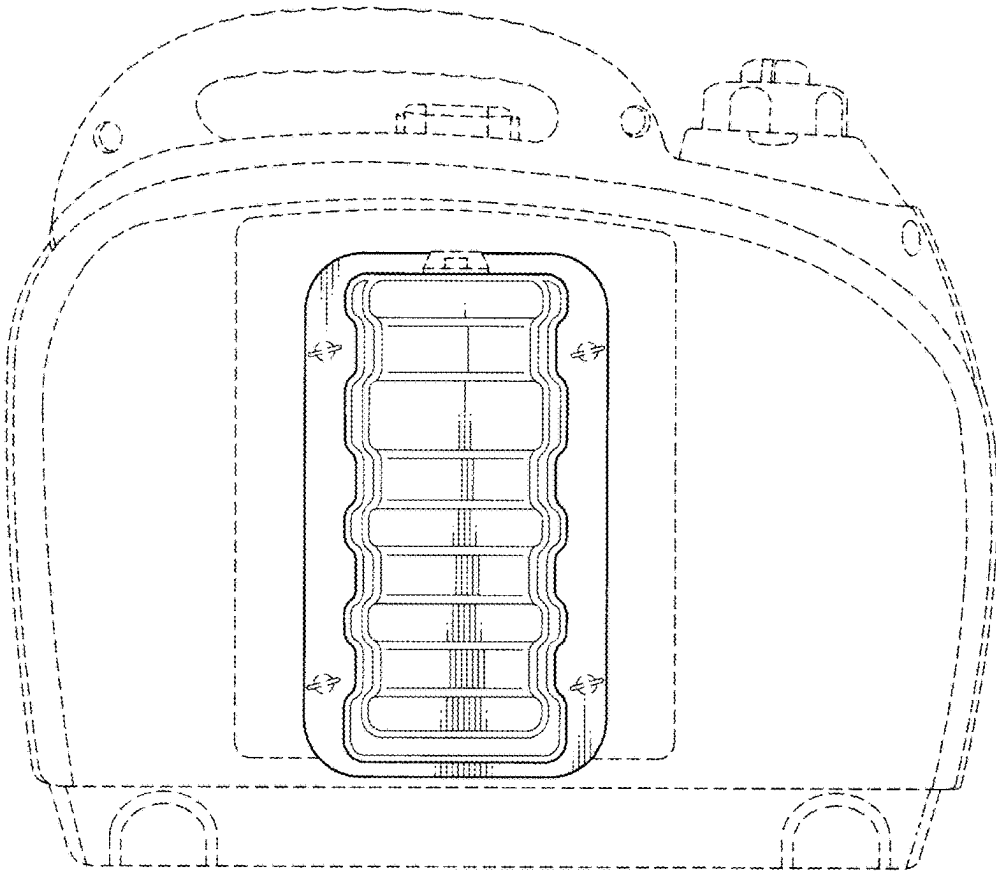
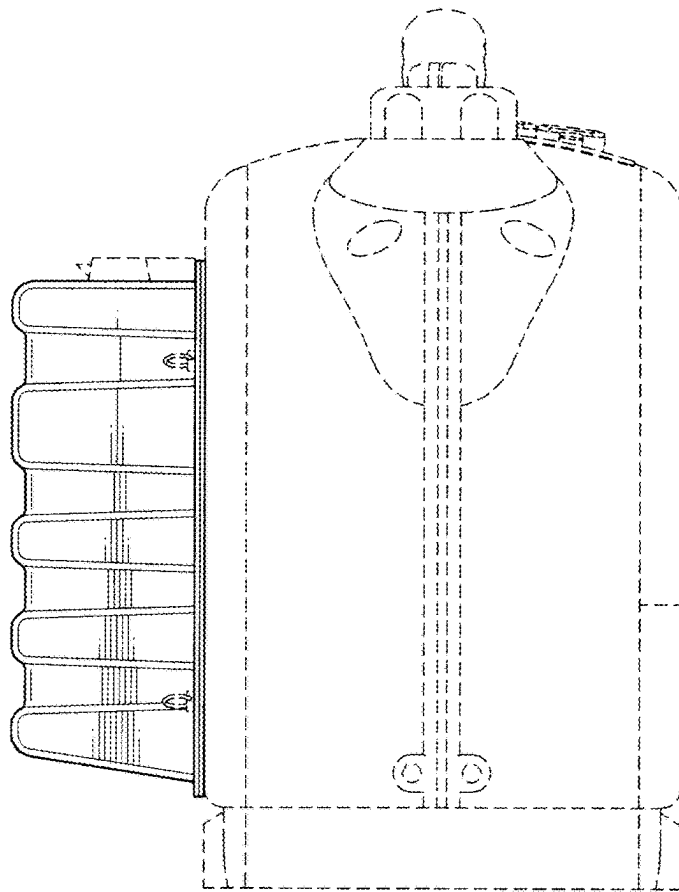
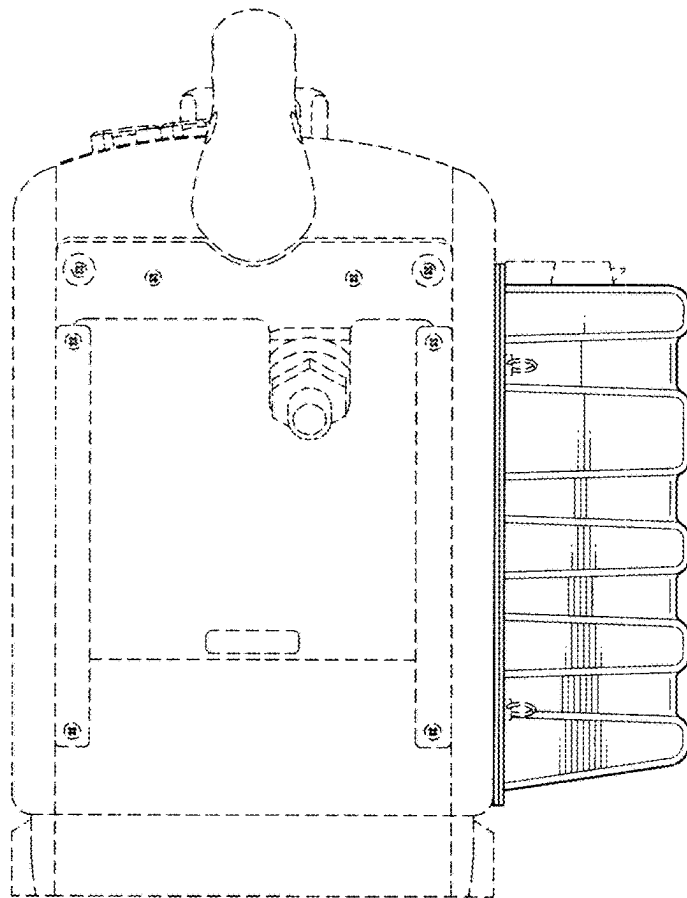

FIG. 2



**FIG. 3**



**FIG. 4**



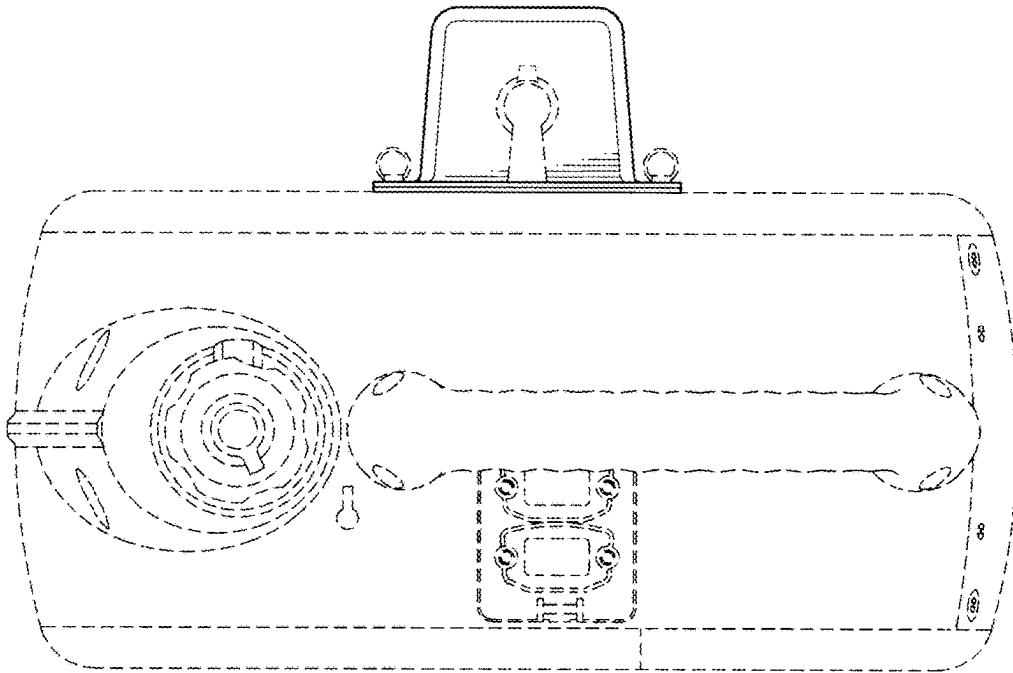

FIG. 5

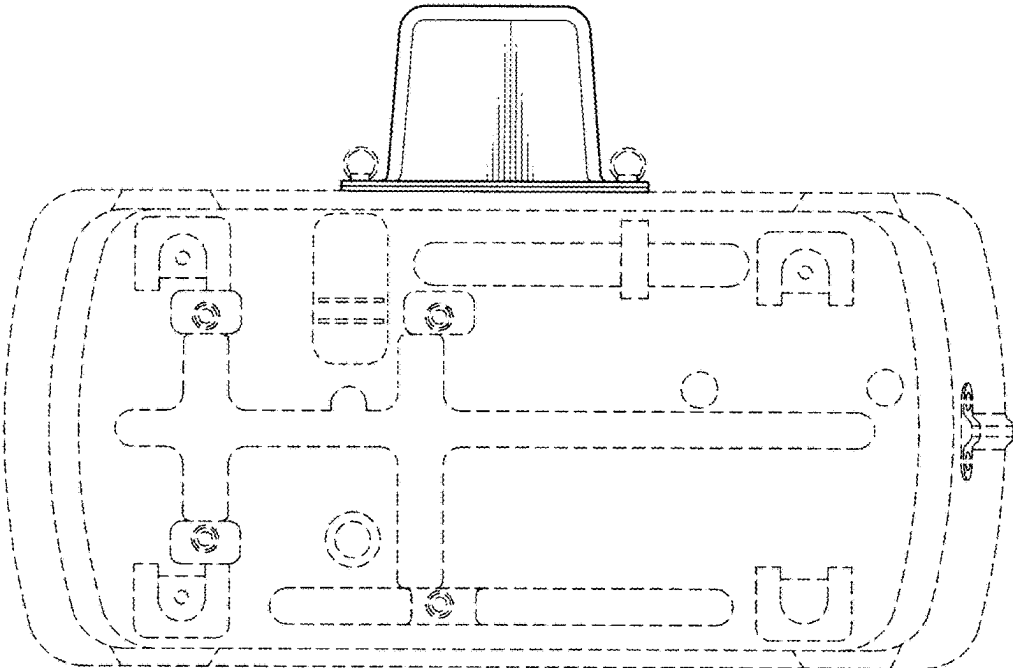
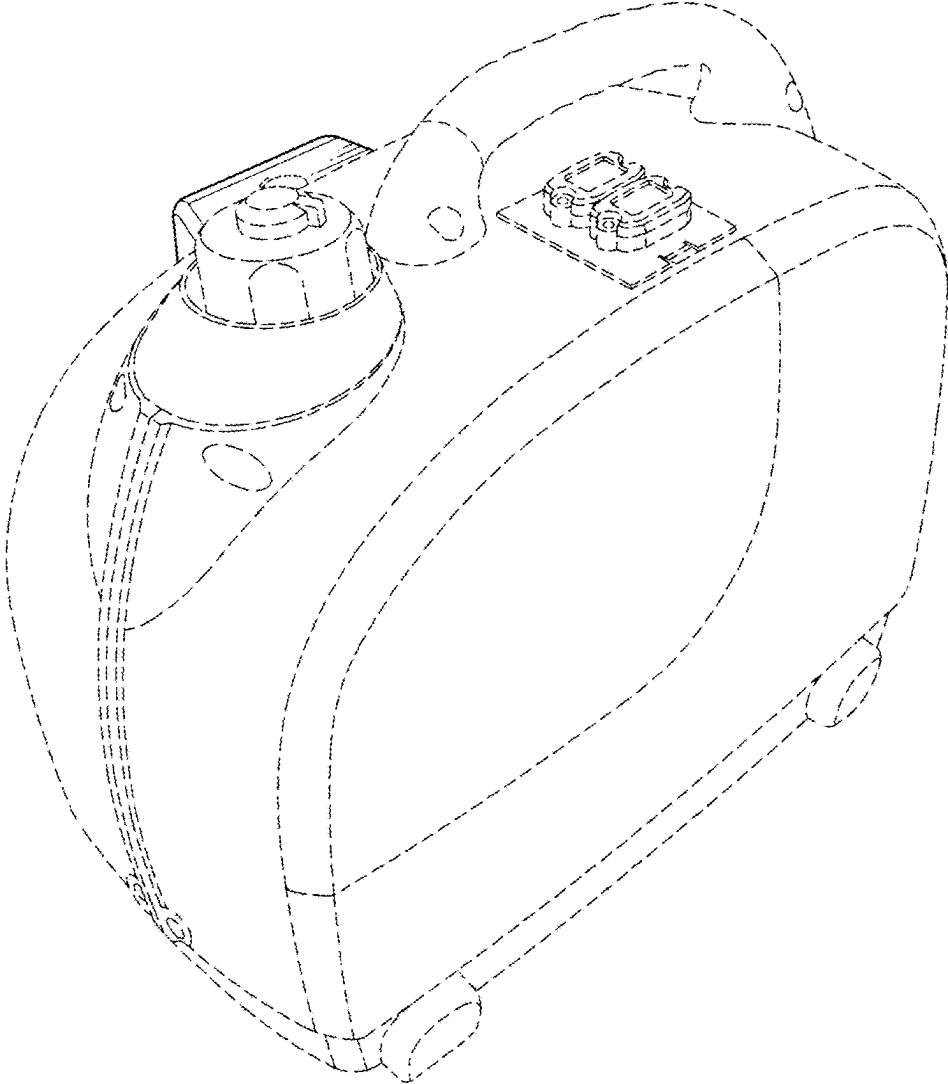
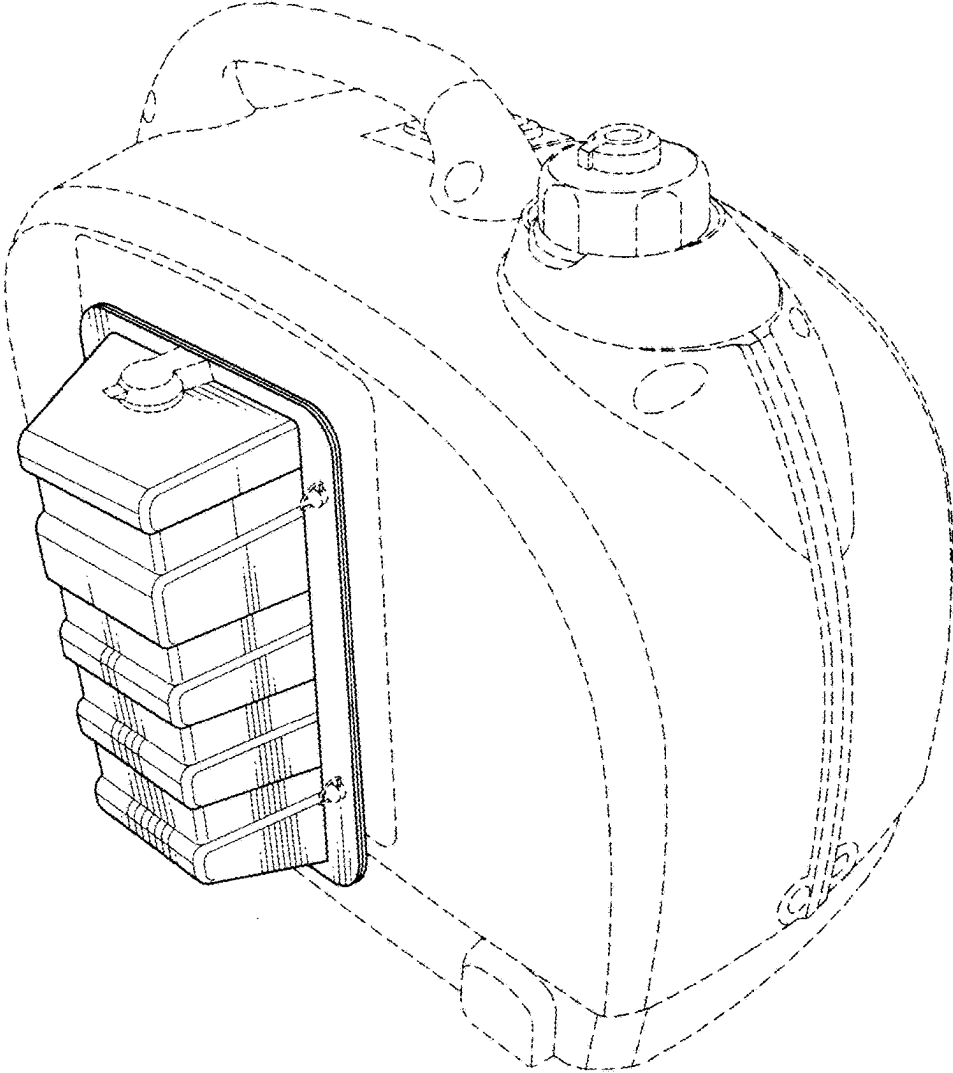

FIG. 6



**FIG. 7**



**FIG. 8**